

TCL101

80V Dual-drive Three-wheel Counterbalance Forklift 1000kg



EP
Let's grow together

- Lightweighted and compact size for smooth operation in extremely tight spaces
- Overhead guard height (h6) <2000mm to work on mezzanines and across floors
- Dual drive motors and three-wheel design deliver sensitive steering and great maneuverability
- Large legroom of 464mm and comfortable seat with armrest for operator comfort
- 80V Li-ion battery and PMSM technology for high efficiency and performance
- Automatic parking brake and turn speed control for safe operation



Manufacturer			EP
Model designation			TCL101
Drive			Electric
Load capacity	Q	kg	1000
Load center distance	c	mm	500
Service weight		kg	1950
Retracted mast height	h1	mm	1990
Lift height	h3	mm	3000
Height, mast extended	h4	mm	3919
Length to face of forks	l2	mm	1684
Overall width	b1/b2	mm	1020
Fork dimensions	s/e/l	mm	35X100X920
Turning radius	Wa	mm	1422
Travel speed, laden/unladen		km/h	11/13
Lifting speed, laden/unladen		m/s	280/350
Lowering speed, laden/unladen		m/s	350/350
Max. gradeability, laden/unladen		%	13/15
Drive motor rating S2 60 min		kW	2.0X2
Battery voltage/nominal capacity		V/Ah	80V/50Ah

FEATURE

■ Compact size with an ample legroom

With its service weight less than 2 tons, compact size, and overhead guard height (h_6) < 2000mm, the TCL101 is ideal for mezzanines and cargo lifts usage and in narrow spaces like intensive warehousing and HGVs. To fit the smallest of spaces, it also provides optional folding forks for increased versatility.

Despite its compactness, the TCL101 prioritizes operator comfort with an ergonomic design, providing an ample legroom of 464mm for a comfortable operating experience.

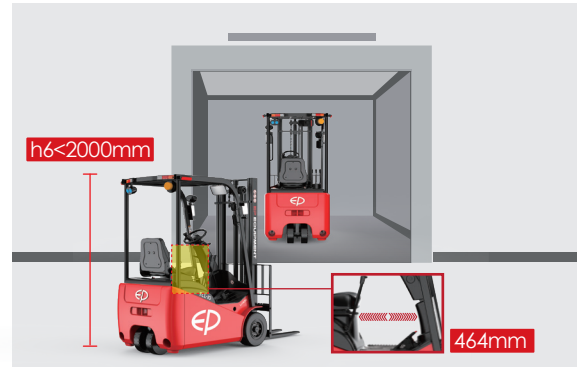

■ Dual drive motors for high agility and performance

The dual drive motors give the TCL101 sensitive steering and the 3-wheel design allows it to turn on the spot. Both contribute to its smaller turning radius of 1422mm and offers great maneuverability in crowded environments. With a top speed of 13km/h, the truck can move pallets quickly and ensures working efficiency.



■ 80V Li-ion battery and PMSM technology for improved efficiency and runtime

Equipped with 80V Li-ion battery and integrated charger as standard, the TCL101 supports opportunity charging with no maintenance. Additionally, the TCL101 employs advanced permanent magnet synchronous motor (PMSM) technology and can achieve 10-15% energy savings and extend runtime by 10% compared to conventional motors.



■ Automatic parking brake and turn speed control for safe operation

The TCL101 features an automatic parking brake which can protect the forklift from accidentally rolling back when parked on a slope. It's also equipped with turn speed control as standard for operation safety and stability even in the tightest of corners.

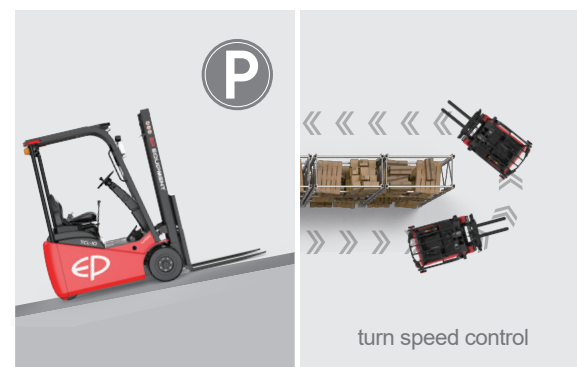

80V Dual-drive Three-wheel Counterbalance Forklift 1000kg

TCL101

Distinguishing mark	1.1	Manufacturer			EP
	1.2	Model designation			TCL101
	1.3	Drive			Electric
	1.4	Operator type			Seated
	1.5	Load capacity	Q	kg	1000
	1.6	Load center distance	c	mm	500
	1.8	Load distance, centre of drive axle to fork	x	mm	310
	1.9	Wheelbase	y	mm	1200
	Service weight	2.1	Service weight		kg
2.2		Axle loading, laden front/rear		kg	2585/365
2.3		Axle loading, unladen front/rear		kg	910/1040
Tyres/chassis	3.1	Tyre type			Solid rubber
	3.2	Tyre size, front			16X6-8
	3.3	Tyre size, rear			3.5-5
	3.5	Wheels, number front/rear (x=drive wheels)		mm	2X/2
	3.6	Tread width, front	b ₁₀	mm	838
	3.7	Tread width, rear	b ₁₁	mm	208
	Dimensions	4.1	Tilt of mast/fork carriage forward/backward	α/β	°
4.2		Retracted mast height	h ₁	mm	1990
4.3		Free lift	h ₂	mm	120
4.4		Lift height	h ₃	mm	3000
4.5		Height, mast extended	h ₄	mm	3919
4.7		Height of overhead guard (cabin)	h ₆	mm	1960
4.8		Seat height/standing height	h ₇	mm	925
4.12		Tow coupling height	h ₁₀	mm	483
4.19		Overall length	l ₁	mm	2604
4.20		Length to face of forks	l ₂	mm	1684
4.21		Overall width	b ₁ /b ₂	mm	1020
4.22		Fork dimensions	s×e×l	mm	35X100X920
4.23		A,B Fork carriage class/type A, B			2A
4.24		Fork carriage width	b ₃	mm	960
4.31		Ground clearance, laden, below mast	m ₁	mm	93
4.32		Ground clearance, center of wheelbase	m ₂	mm	89
4.34.1		Aisle width for pallets 1000×1200 crossways	Ast	mm	3063
4.34.2		Aisle width for pallets 800×1200 lengthways	Ast	mm	3184
4.35		Turning radius	Wa	mm	1422
Performance data		5.1	Travel speed, laden/unladen		km/h
	5.2	Lifting speed, laden/unladen		m/s	280/350
	5.3	Lowering speed, laden/unladen		m/s	350/350
	5.8	Max. gradeability, laden/unladen		%	13/15
	5.10	Service brake			Electromagnetic
	5.11	Parking brake			Electromagnetic
Electric-engine	6.1	Drive motor rating S2 60 min		kW	2.0X2
	6.2	Lift motor rating at S3 15%		kW	7
	6.4	Battery voltage/nominal capacity		V/Ah	80V/50Ah
	6.5	Battery weight		kg	65
	10.5	Steering design			Hydraulic
	10.7	Sound pressure level at the driver's ear			dB(A)

If there are improvements of technical parameters or configurations, no further notice will be given.
The diagram shown may contain non-standard configurations.

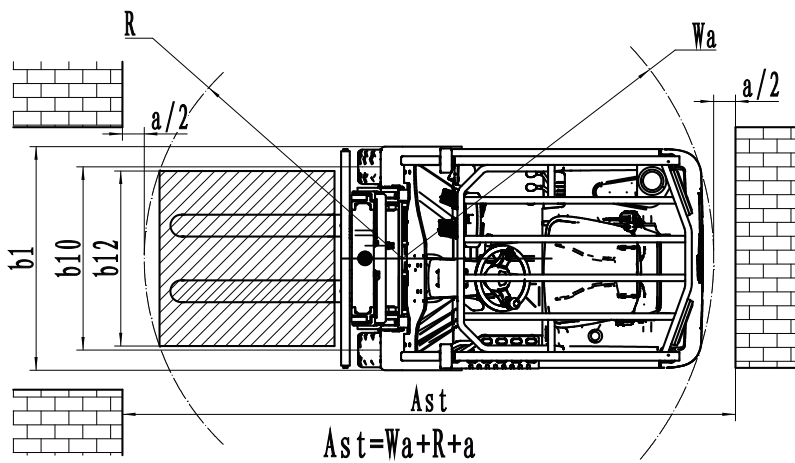
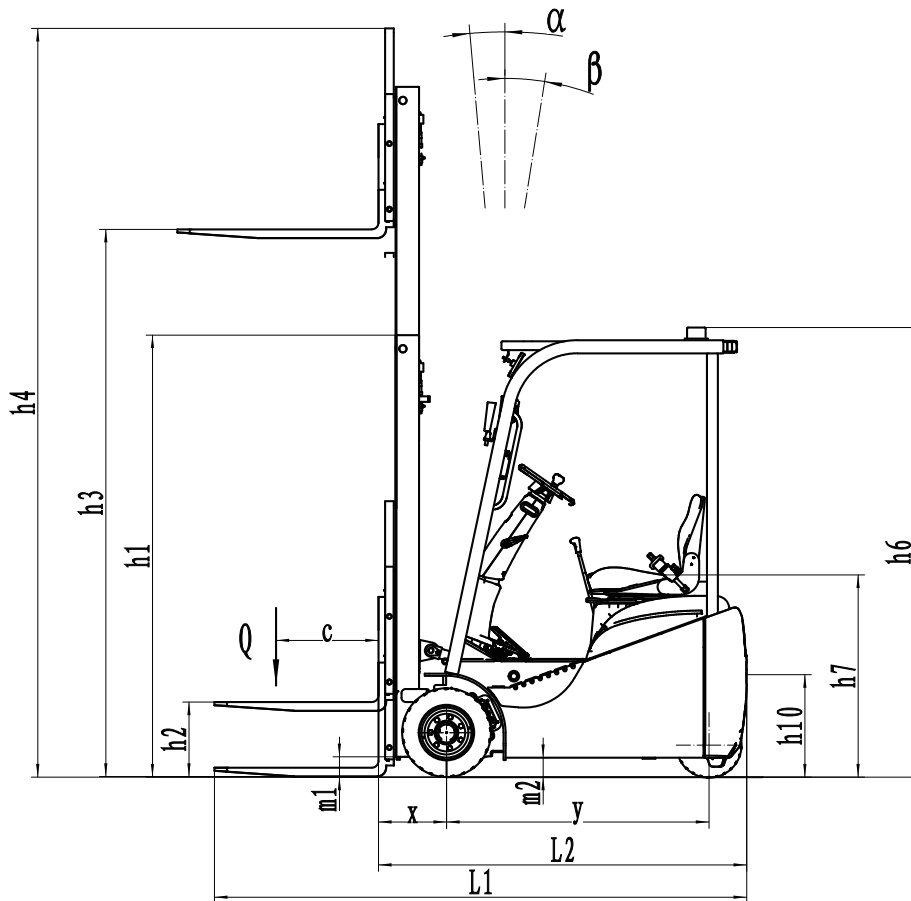

RATED CAPACITIES AND LOAD CENTERES GRAPH

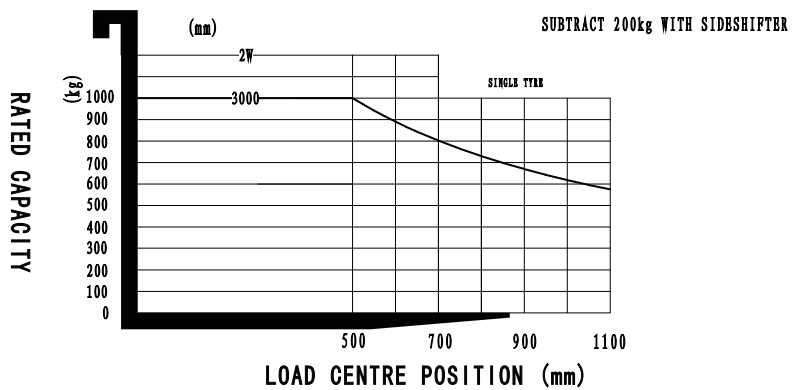

Mast Option

Mast types	Lift height (h3)	Height, Mast			Height, Free lift(h2)	
		Height, mast lowered(h1)	Height, mast extended(h4)		No backrest	With backrest
	No backrest		With backrest	mm		
2-Standard Mast	2500	1811	-	3408	-	-
	2700	1911	-	3608	-	-
	3000	2061	-	3908	-	-
	3300	2211	-	4211	-	-

Option

Optional items	TCL101
Fork dimension	●600*600, 2A、100*35*920●600*600, 2A、100*35*750 ○600*600, 2A、100*35*1070○900*600, 2A、100*40*1150 ○900*600、2A、100*40*1220
Front wheel material	○Normal solid○Non-marking solid
Rear wheel material	○Normal solid○Non-marking solid
Battery capacity	●80V50Ah○80V100Ah
Charger	●80V-35A Single-phase built-in charger
Battery display indicator (BDI)	●With hourmeter
Seat type	●Regular+ safety belt switch ○Comfortable + safety belt switch○Suspension + safety belt switch
Attachments	●No○Built-in sideshifter○External shifter
clamp interlock	●No
Traction pin	●Yes and not customized
Anti-static chain	●Yes and not customized
Front lamp	●LED
Rear lamp	●No○LED
Warning lamp	●Yes and not customized
Turn signal light	●LED
Blue lamp	●No○Rear○Front○Front and rear
Area warning lamp	●No○Both side○Both side and rear
Rearview mirror	●One in front○Two on sides and one in front
Buzzer	●Yes and not customized
OPS system	●Yes and not customized
USB interface	●No
Telematics	●Yes and not customized
Speed reduction for elevated mast- Australian standard	●No○Only for Australia standard
Turn speed control	●Yes and not customized
Heating system during lithium battery charging	●No○Yes and not customized
Operator identification device	○Card reader
Lifting electronic limit	●No
Hydraulic control	●Mechanical lever
Rear armrest horn	●No
Cabin	●No
Overhead guard	●Yes and not customized

Note: ●Standard ○Optional - Inconformity