

3-wheel Pneumatic Forklift 4,000lbs TDL201



- Chassis designed exclusively for the EP Energy 48V lithium battery
- Dual AC drive motors for exceptional maneuverability
- Lithium chassis affords superior ergonomics in seating position and visibility
- EP exclusive LED Display provides intuitive information
- Wide variety of chargers from 25A to 150A

Manufacturer				EP
Model designation				TDL201
Drive				Electric
Base capacity	Q	lb.	4000	
Load center distance	c	in.	24	
Service weight		lb.	8415	
Collapsed Height	h1	in.	81.7	
Maximum fork height	h3	in.	189	
Height, mast extended with Std. LBR	h4	in.	230	
Length to face of forks	l2	in.	80	
Overall width	b1/b2	in.	45.3	
Fork dimensions	s/e/l	in.	1.6x4.8x42.1	
Turning radius	Wa	in.	63.2	
Travel speed, loaded/unloaded		mph	9.3/9.9	
Lifting speed, loaded/unloaded		fpm	68.9/84.6	
Lowering speed, loaded/unloaded		fpm	88.6/72.8	
Max. gradeability, loaded/unloaded		%	15/17	
Drive motor rating S2 60 min		kW	5.4x2	
Battery voltage/nominal capacity		V/Ah	48V/360Ah	

FEATURES

Hydraulic steering system with better human-vehicle interaction

The TDL201 adopts the hydraulic steering system and this achieves more precise and responsive operation, which demonstrates better human-vehicle interaction. Plus, the hydraulic steering system comes with a simple and reliable structure with lower maintenance costs.



Larger legroom to amplify driving comfort

The integrated design of the operator compartment allows for a larger operational space to improve ergonomics and to reduce operator fatigue.



Dual AC Drive Motors

Independently controlled dual drive motors allows nimble control in tight spaces for superior right-angle stack and truck maneuverability.

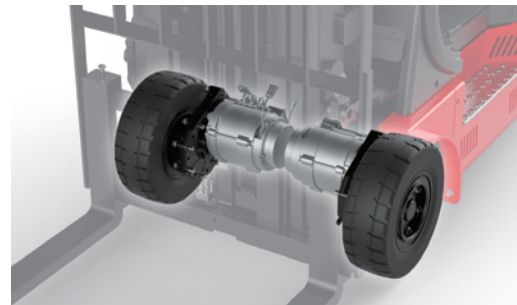

Informative LED display

The platform provides a high-resolution LED display installed in the upper right corner of the cabin. At a glance, the operator can view speed, directional status, battery state-of-charge, hour meter, and more.



3-wheel Pneumatic Forklift 4,000lbs TDL201

Distinguishing mark	1.1	Manufacturer				EP
	1.2	Model designation				TDL201
	1.3	Drive				Electric
	1.4	Operator type				Seated
	1.5	Base capacity	Q	lb.		4000
	1.6	Load center distance	c	in.		24
	1.8	Load distance, center of drive axle to fork	x	in.		16.6
	1.9	Wheelbase	y	in.		53.5
	Service weight	2.1	Service weight		lb.	
2.2		Axle loading, loaded front/rear		lb.		11131/1283
2.3		Axle loading, unloaded front/rear		lb.		4065/4349
Tires/chassis	3.1	Tire type				Solid pneumatic
	3.2	Tire size, front				200/50-10
	3.3	Tire size, rear				15/4.5-8
	3.5	Wheels, number front/rear (x=drive wheels)		in.		2X/2
	3.6	Tread width, front	b ₁₀	in.		36.9
	3.7	Tread width, front	b ₁₁	in.		6.9
	Dimensions	4.1	Tilt of mast/fork carriage forward/backward	α/β	°	
4.2		Collapsed Height	h ₁	in.		81.7
4.3		Free lift	h ₂	in.		47.8
4.4		Maximum fork height	h ₃	in.		189
4.5		Height, mast extended with Std. LBR	h ₄	in.		230
4.7		Height of overhead guard (cabin)	h ₆	in.		84.3
4.8		Seat height/standing height	h ₇	in.		42
4.12		Tow coupling height	h ₁₀	in.		22
4.19		Overall length	l ₁	in.		122
4.20		Length to face of forks	l ₂	in.		80
4.21		Overall width	b/b ₂	in.		45.3
4.22		Fork dimensions	s×e×l	in.		1.6x4.8x42.1
4.23		A,B Fork carriage class/type A, B				2A
4.24		Fork carriage width	b ₃	in.		41
4.31		Ground clearance, laden, below mast	m ₁	in.		3.4
4.32		Ground clearance, center of wheelbase	m ₂	in.		4.1
4.34.1		Right angle stack = X+Wa		in.		79.8
4.34.2	Minimum Aisle Width (Right Angle Stack + Load Length + Clearance)		in.		139.8	
4.35	Turning radius	Wa	in.		63.2	
Performance data	5.1	Travel speed, laden/unladen		mph		9.3/9.9
	5.2	Lifting speed, loaded/unloaded		fpm		68.9/84.6
	5.3	Lowering speed, loaded/unloaded		fpm		88.6/72.8
	5.8	Max. gradeability, loaded/unloaded		%		15/17
	5.10	Service brake				Regen
	5.11	Parking brake				Electromagnetic
Electric-engine	6.1	Drive motor rating S2 60 min		kW		5.4X2
	6.2	Lift motor rating at S3 15%		kW		11
	6.4	Battery voltage/nominal capacity		V/Ah		48V/360Ah
	6.5	Battery weight		lb.		456 min
	6.6	Energy consumption according to DIN EN 16796		kWh		5.228 ¹⁾
	6.7	Turnover output according to VDI 2198		lb/h		120
	6.8	Turnover efficiency according to VDI 2198		lb/kWh		22.69
	Additional data	8.1	Type of drive control			
10.5		Steering design				Hydraulic
10.7		Sound pressure level at the driver's ear		dB(A)		79
15.1		Charger output current		A		25, 50, 150

If there are improvements of technical parameters or configurations, no further notice will be given.
The diagram shown may contain non-standard configurations.
Minimum Aisle Width uses 48" for load length and 12" for Clearance.

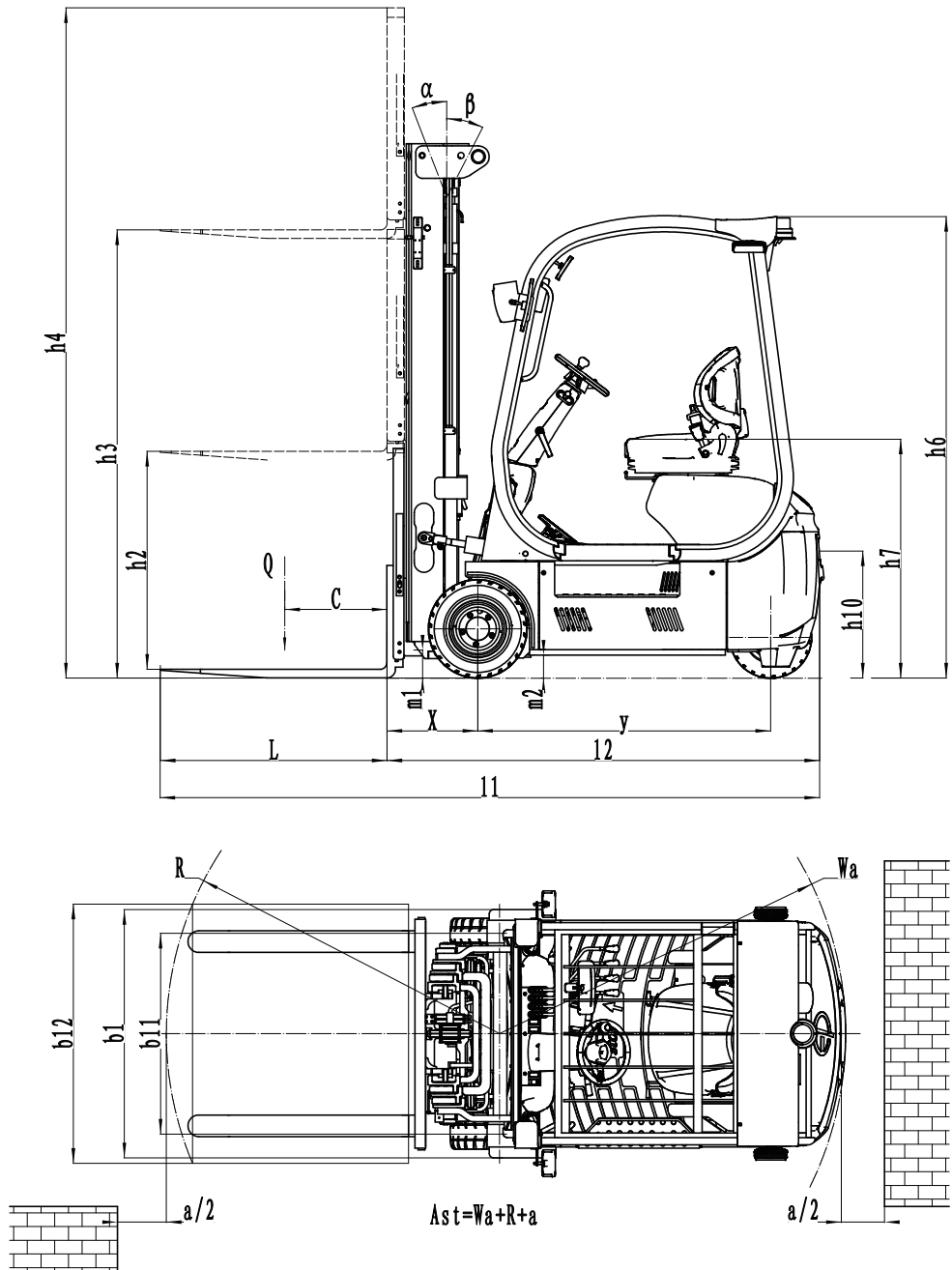

Mast Options

Mast types	Lift height (h3)	Height, Mast			Height, Free lift(h2)	
		Height, mast lowered(h1)	Height, mast extended(h4)		No shelving	With shelving
			No shelving	With shelving		
	in.	in.	in.	in.	in.	in.
3-Free Mast	189	88.2	218.1	230.5	60.2	47.8
	197	90.7	226	238.4	62.8	50.4