

EPX5-251,301, 351,381 Electric Counterbalance Forklift Truck 2500-3800kg

EP
Let's grow together



- **Modular battery design for flexible battery capacity adjustment**
- **One standard battery module allows for individual use and pairwise combination**
- **Lithium technology with opportunity charging and zero maintenance**
- **High travelling and lifting speed and strong gradeability for maximum efficiency**
- **150mm ground clearance and big tyres to work on all surfaces**
- **Improved key components: mast, lights, seat, display and controls**

Manufacturer			EP	EP	EP	EP
Model designation			EPX5-251	EPX5-301	EPX5-351	EPX5-381
Drive			Electric	Electric	Electric	Electric
Load capacity	Q	kg	2500	3000	3500	3800
Load center distance	c	mm	500	500	500	500
Service weight		kg	3835	4820	5020	5350
Retracted mast height	h1	mm	2090	2065	2065	2065
Lift height	h3	mm	3000	3000	3000	3000
Height, mast extended	h4	mm	4065	4130	4130	4130
Length to face of forks	l2	mm	2520	2749	2754	2795
Overall width	b1/b2	mm	1154	1230	1230	1250
Fork dimensions	s×e×l	mm	40×122×1070	45×122×1070	50×122×1070	50×122×1070
Turning radius	Wa	mm	2270	2498	2498	2524
Travel speed, laden/unladen		km/h	16/17	16/17	16/17	15/16
Lifting speed, laden/unladen		m/s	0.38/0.45	0.45/0.55	0.44/0.55	0.43/0.52
Lowering speed, laden/unladen		m/s	0.45/0.52	0.5/0.44	0.5/0.44	0.5/0.4
Max. gradeability, laden/unladen		%	17/25	20/25	18/25	16/20
Drive motor rating S2 60 min		kW	16	16	16	16
Battery voltage/nominal capacity		V/Ah	80V280AH	80V280AH	80V280AH	80V280AH

Modular Li-ion battery design for maximum flexibility

The EFX5 series features a modular Li-ion battery design and offers one standard lithium battery module of 280Ah. The truck can accommodate up to two battery modules and through pairwise combination, you can get one more battery capacity 560Ah. This allows for flexibly adjusting battery capacities to meet different application requirements from light to heavy duties.



■ Optimize stock management

Modular battery design enables offering medium to high battery capacities in one truck to fit various endurance demands. This helps dealers reduce fixed assets, manage stockpile effectively and respond quickly to different users needs by simply installing the second battery module.



■ Longer endurance in peak season

The user needs in terms of daily usage of the truck may change over the years or there may be a peak during harvesting or on a specific season. The modular battery system makes it easy to retrofit an additional battery, providing additional sales or short-term rental opportunities.



■ Ensure uninterrupted operation

Double batteries mean double guarantee. When one battery is down, another one can seamlessly power the EFX5 truck, minimizing downtime risks associated with battery and ensuring continuous, smooth handling operation.

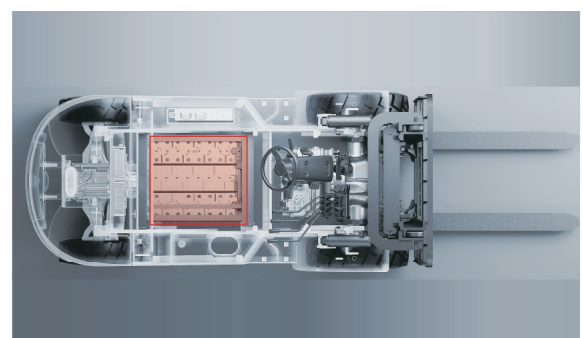

FEATURE

High performance for productivity boost

The EFX5 series demonstrates high performance comparable to EFL303S to enhance goods turnover efficiency.

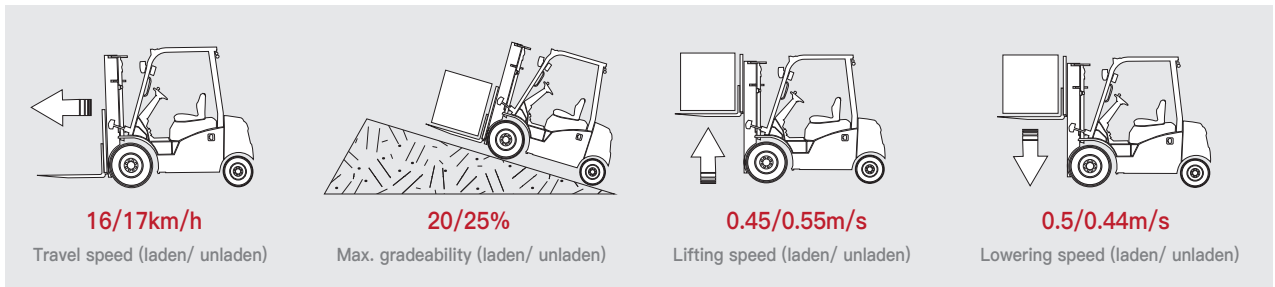

Lithium technology with opportunity charging

The EFX5 series is designed around the advantages of lithium technology and meets the requirements of sustainable development. It supports opportunity charging and zero maintenance to minimize downtime.



Higher ground clearance for all terrain challenges

The EFX5 series provides higher ground clearance of 150mm and big tyres, protecting the forklift from getting stuck on ramps, potholes and mud. It's a workhorse to handle loads on all terrains.



Improved components for easy, safe and comfortable operation

The EFX5 series is equipped with improved components such as the new triplex mast with high visibility, the new seat with armrest, the new LED front lights, the wider brake pedal and the large LED display.



Electric Counterbalance Forklift Truck 2500-3800kg

EFX5-251,301,351,381

Distinguishing mark	1.1	Manufacturer			EP	EP	EP	EP
	1.2	Model designation			EFX5-251	EFX5-301	EFX5-351	EFX5-381
	1.3	Drive			Electric	Electric	Electric	Electric
	1.4	Operator type			Seated	Seated	Seated	Seated
	1.5	Load capacity	Q	kg	2500	3000	3500	3800
	1.6	Load center distance	c	mm	500	500	500	500
	1.8	Load distance, centre of drive axle to fork	x	mm	495	481	486	501
	1.9	Wheelbase	y	mm	1685	1760	1760	1760
	Service weight	2.1	Service weight		kg	3835	4820	5020
2.2		Axle loading, laden front/rear		kg	5679/656	6510/1310	7290/1230	7910/1240
2.3		Axle loading, unladen front/rear		kg	1711/2124	1835/2985	1810/3210	1950/3400
Tyres/chassis	3.1	Tyre type			Pneumatic	Pneumatic	Pneumatic	Solid rubber
	3.2	Tyre size, front			7.00-12-12PR	28X9-15-14PR	28X9-15-14PR	250-15
	3.3	Tyre size, rear			18X7-8-14PR	6.50-10-10PR	6.50-10-10PR	6.50-10
	3.5	Wheels, number front/rear (x=drive wheels)		mm	2x/ 2	2x/ 2	2x/ 2	2x/ 2
	3.6	Tread width, front	b ₁₀	mm	975	1010	1010	1010
	3.7	Tread width, rear	b ₁₁	mm	955	980	980	980
	4.1	Tilt of mast/fork carriage forward/backward	α/β	°	6/ 10	6/ 10	6/ 10	6/ 10
Dimensions	4.2	Retracted mast height	h ₁	mm	2090	2065	2065	2065
	4.3	Free lift	h ₂	mm	195	135	135	135
	4.4	Lift height	h ₃	mm	3000	3000	3000	3000
	4.5	Height, mast extended	h ₄	mm	4065	4130	4130	4130
	4.7	Height of overhead guard (cabin)	h ₆	mm	2165	2160	2160	2160
	4.8	Seat height/standing height	h ₇	mm	1095	1095	1095	1095
	4.12	Tow coupling height	h ₁₀	mm	315	280	280	280
	4.19	Overall length	l ₁	mm	3590	3819	3824	3865
	4.20	Length to face of forks	l ₂	mm	2520	2749	2754	2795
	4.21	Overall width	b ₁ /b ₂	mm	1154	1230	1230	1250
	4.22	Fork dimensions	s×e×l	mm	40×122×1070	45×122×1070	50×122×1070	50×122×1070
	4.23	A,B Fork carriage class/type A, B			2A	3A	3A	3A
	4.24	Fork carriage width	b ₃	mm	1040	1100	1100	1100
	4.31	Ground clearance, laden, below mast	m ₁	mm	100	120	120	120
	4.32	Ground clearance, center of wheelbase	m ₂	mm	150	150	150	150
	4.34.1	Aisle width for pallets 1000×1200 crossways	Ast	mm	3965	4179	4184	4225
	4.34.2	Aisle width for pallets 800×1200 lengthways	Ast	mm	4165	4379	4384	4425
4.35	Turning radius	Wa	mm	2270	2498	2498	2524	
Performance data	5.1	Travel speed, laden/unladen		km/h	16/17	16/17	16/17	15/16
	5.2	Lifting speed, laden/unladen		m/s	0.38/0.45	0.45/0.55	0.44/0.55	0.43/0.52
	5.3	Lowering speed, laden/unladen		m/s	0.45/0.52	0.5/0.44	0.5/0.44	0.5/0.4
	5.8	Max. gradeability, laden/unladen		%	17/25	20/25	18/25	16/20
	5.10	Service brake			Hydraulic	Hydraulic	Hydraulic	Hydraulic
	5.11	Parking brake			Mechanical	Mechanical	Mechanical	Mechanical
Electric-engine	6.1	Drive motor rating S2 60 min		kW	16	16	16	16
	6.2	Lift motor rating at S3 15%		kW	24	24	24	24
	6.4	Battery voltage/nominal capacity		V/Ah	80V280AH	80V280AH	80V280AH	80V280AH
Drive/lift mechanism	8.1	Type of drive control			AC	AC	AC	AC
	10.5	Steering design			Hydraulic	Hydraulic	Hydraulic	Hydraulic
Addition data	10.7	Sound pressure level at the driver's ear		dB(A)	< 74	< 74	< 74	< 74

If there are improvements of technical parameters or configurations, no further notice will be given.
The diagram shown may contain non-standard configurations.

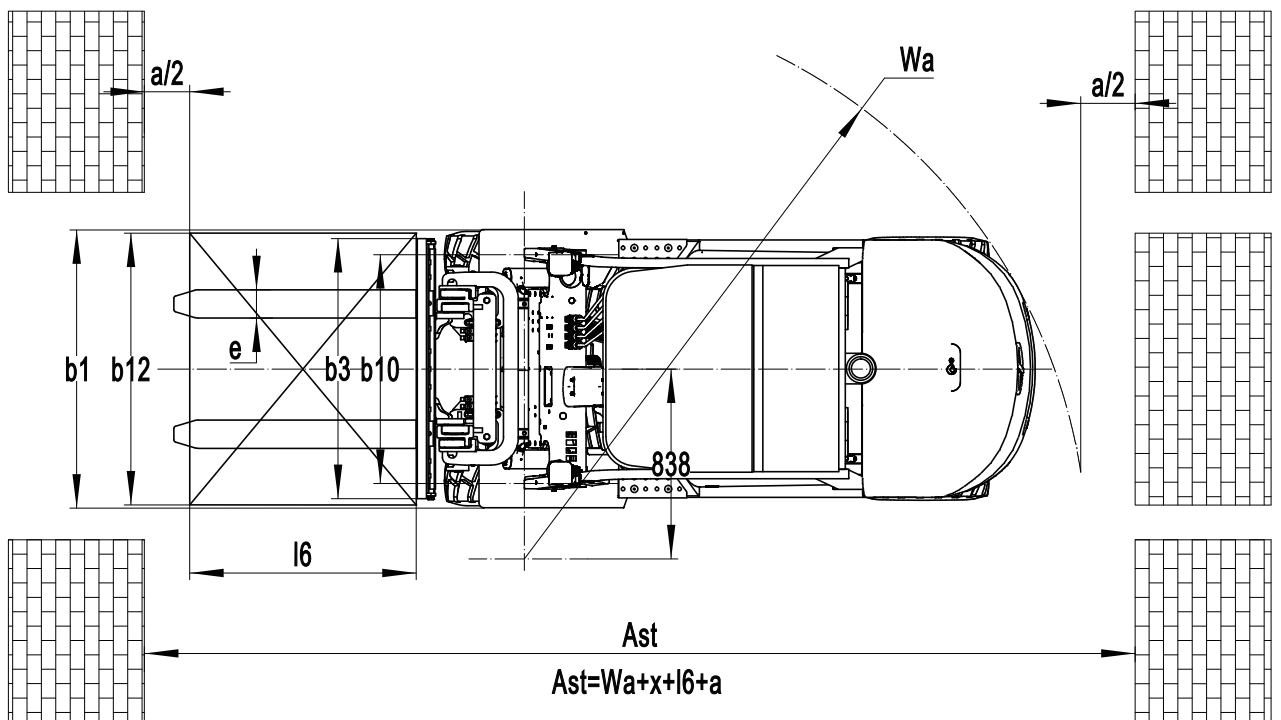
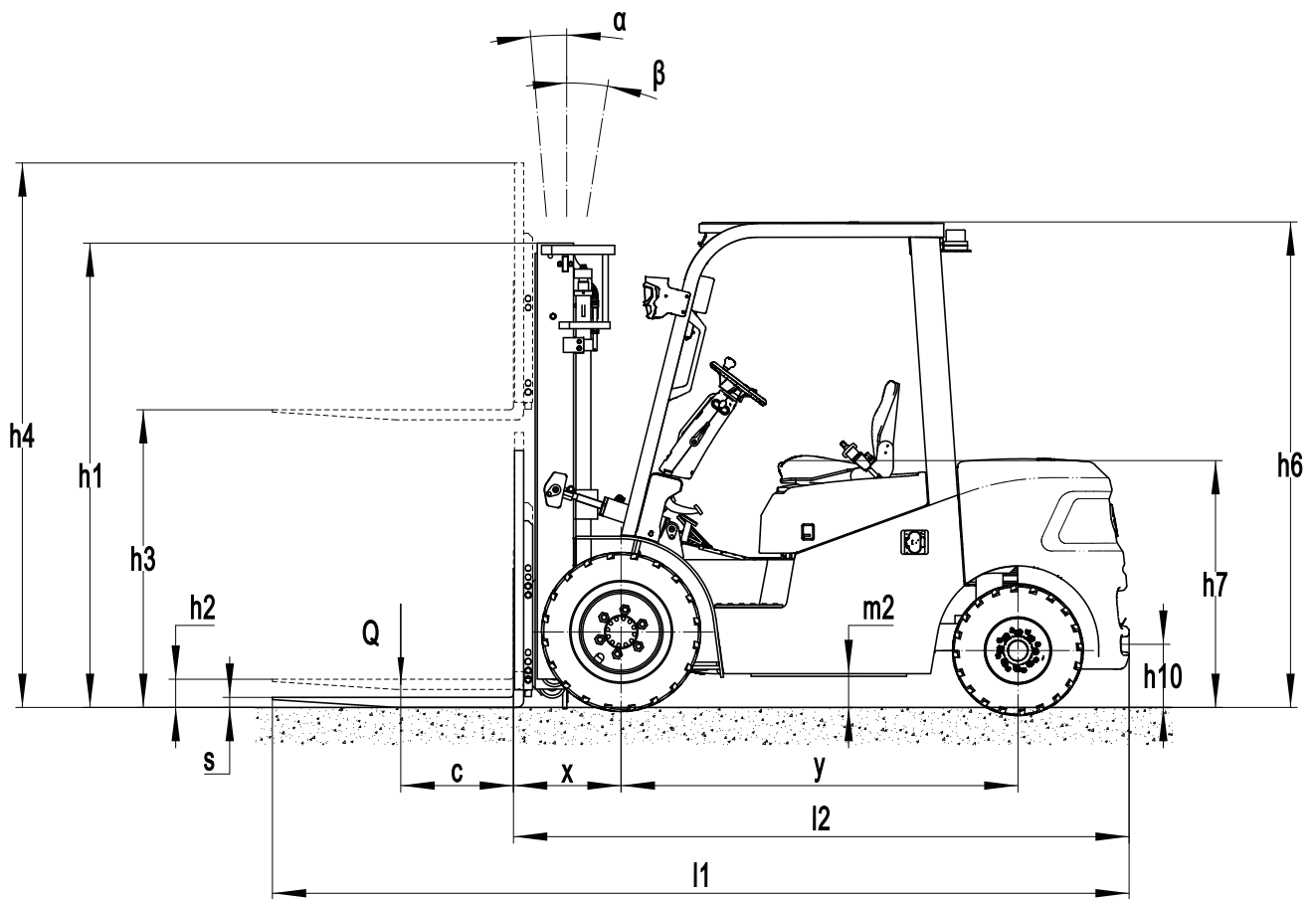

Mast Option

EFX5-251

Mast types	Lift height (h3)	Height, Mast			Height, Free lift(h2)	
		Height, mast lowered(h1)	Height, mast extended(h4)		No shelving	With shelving
	mm		mm	mm		
2-Standard Mast	3000	2090	3595	4060	195	195
	3300	2240	3895	4360	195	195
	3500	2340	4095	4560	195	195
	3600	2390	4195	4660	195	195
	4000	2640	4595	5060	195	195
	4500	2890	5095	5560	195	195
2-Free Mast	3000	2035	3765	4100	1345	1010
	3300	2185	4065	4400	1495	1160
	3600	2335	4365	4700	1645	1310
3-Free Mast	4300	2080	5040	5355	1370	1055
	4500	2160	5280	5595	1450	1135
	4800	2265	5580	5895	1555	1240
	5000	2350	5730	6045	1640	1325
	5500	2600	6230	6545	1890	1575
	6000	2850	6730	7045	2140	1825

EFX5-301

Mast types	Lift height (h3)	Height, Mast			Height, Free lift(h2)	
		Height, mast lowered(h1)	Height, mast extended(h4)		No shelving	With shelving
	mm		mm	mm		
2-Standard Mast	3000	2065	3665	4130	135	135
	3300	2215	3965	4430	135	135
	3500	2315	4165	4630	135	135
	3600	2365	4265	4730	135	135
	4000	2615	4665	5130	135	135
	4500	2865	5165	5630	135	135
2-Free Mast	3000	2045	3715	4175	1410	950
	3300	2195	4015	4475	1560	1100
	3600	2345	4315	4775	1710	1250
3-Free Mast	4300	2080	5030	5435	1390	985
	4500	2160	5270	5675	1470	1065
	4800	2265	5570	5975	1575	1170
	5000	2350	5720	6125	1660	1255
	5500	2600	6220	6625	1910	1505
	6000	2850	6720	7125	2160	1755

EFX5-351

Mast types	Lift height (h3)	Height, Mast			Height,Free lift(h2)	
		Height, mast lowered(h1)	Height, mast extended(h4)		No shelving	With shelving
	No shelving		With shelving	mm		
2-Standard Mast	3000	2065	3665	4130	135	135
	3300	2215	3965	4430	135	135
	3500	2315	4165	4630	135	135
	3600	2365	4265	4730	135	135
	4000	2615	4665	5130	135	135
	4500	2865	5165	5630	135	135
2-Free Mast	3000	2045	3715	4175	1410	950
	3300	2195	4015	4475	1560	1100
	3600	2345	4315	4775	1710	1250
3-Free Mast	4300	2080	5030	5435	1390	985
	4500	2160	5270	5675	1470	1065
	4800	2265	5570	5975	1575	1170
	5000	2350	5720	6125	1660	1255
	5500	2600	6220	6625	1910	1505
	6000	2850	6720	7125	2160	1755

EFX5-381

Mast types	Lift height (h3)	Height, Mast			Height,Free lift(h2)	
		Height, mast lowered(h1)	Height, mast extended(h4)		No shelving	With shelving
	No shelving		With shelving	mm		
2-Standard Mast	3000	2065	3665	4130	135	135
	3300	2215	3965	4430	135	135
	3500	2315	4165	4630	135	135
	3600	2365	4265	4730	135	135
	4000	2615	4665	5130	135	135
	4500	2865	5165	5630	135	135
2-Free Mast	3000	2045	3715	4175	1410	950
	3300	2195	4015	4475	1560	1100
	3600	2345	4315	4775	1710	1250
3-Free Mast	4300	2080	5030	5435	1390	985
	4500	2160	5270	5675	1470	1065
	4800	2265	5570	5975	1575	1170
	5000	2350	5720	6125	1660	1255
	5500	2600	6220	6625	1910	1505
	6000	2850	6720	7125	2160	1755

Option:

Optional items	EFX 5-251	EFX5-301	EFX5-351	EFX5-381
Fork dimension	<ul style="list-style-type: none"> ○122*40*920 ●122*40*1070 ○122*40*1150 ○122*40*1220 ○122*40*1370 ○122*40*1500 ○122*40*1600 ○122*40*1700 ○122*40*1820 ○122*40*1900 ○122*40*2000 ○122*40*2200 	<ul style="list-style-type: none"> ●122*45*1070 ○122*45*1150 ○122*45*1220 ○122*45*1370 ○122*45*1520 ○122*45*1600 ○122*45*1700 ○122*45*1820 ○122*45*2000 ○122*45*2200 ○122*45*2400 	<ul style="list-style-type: none"> ●122*50*1070 ○122*50*1150 ○122*50*1220 ○122*50*1370 ○122*50*1520 ○122*50*1600 ○122*50*1700 ○122*50*1820 ○122*50*2000 ○122*50*2200 ○122*50*2420 	<ul style="list-style-type: none"> ●122*50*1070 ○122*50*1150 ○122*50*1220 ○122*50*1370 ○122*50*1520 ○122*50*1600 ○122*50*1700 ○122*50*1820 ○122*50*2000 ○122*50*2200 ○122*50*2420
Front wheel material	<ul style="list-style-type: none"> ○Pneumatic ○Normal solid ○Traceless solid 	<ul style="list-style-type: none"> ○Pneumatic ○Normal solid ○Traceless solid 	<ul style="list-style-type: none"> ○Pneumatic ○Normal solid ○Traceless solid 	<ul style="list-style-type: none"> ○Normal solid ○Traceless solid
Rear wheel material	<ul style="list-style-type: none"> ○Pneumatic ○Normal solid ○Traceless solid 	<ul style="list-style-type: none"> ○Pneumatic ○Normal solid ○Traceless solid 	<ul style="list-style-type: none"> ○Pneumatic ○Normal solid ○Traceless solid 	<ul style="list-style-type: none"> ○Normal solid ○Traceless solid
Battery capacity	<ul style="list-style-type: none"> ○80V280AH ○80V280AH*2 	<ul style="list-style-type: none"> ●80V280AH ○80V280AH*2 	<ul style="list-style-type: none"> ●80V280AH ○80V280AH*2 	<ul style="list-style-type: none"> ●80V280AH ○80V280AH*2
Charger	<ul style="list-style-type: none"> ○80V35A Internal ○80V60A Internal ○80V65A ○80V100A ○80V150A ○80V200A (only for 280AH*2 battery) 	<ul style="list-style-type: none"> ○80V35A Internal ○80V60A Internal ○80V65A ○80V100A ○80V150A ○80V200A (only for 280AH*2 battery) 	<ul style="list-style-type: none"> ○80V35A Internal ○80V60A Internal ○80V65A ○80V100A ○80V150A ○80V200A (only for 280AH*2 battery) 	<ul style="list-style-type: none"> ○80V35A Internal ○80V60A Internal ○80V65A ○80V100A ○80V150A ○80V200A (only for 280AH*2 battery)
Battery display indicator (BDI)	<ul style="list-style-type: none"> ●With hourmeter (Bluetooth) without ESP ○With hourmeter (Bluetooth) with ESP 	<ul style="list-style-type: none"> ●With hourmeter (Bluetooth) without ESP ○With hourmeter (Bluetooth) with ESP 	<ul style="list-style-type: none"> ●With hourmeter (Bluetooth) without ESP ○With hourmeter (Bluetooth) with ESP 	<ul style="list-style-type: none"> ●With hourmeter (Bluetooth) without ESP ○With hourmeter (Bluetooth) with ESP
Seat type	<ul style="list-style-type: none"> ○Comfortable + safety belt switch ○Seat with armrest with safety belt switch 	<ul style="list-style-type: none"> ○Comfortable + safety belt switch ○Seat with armrest with safety belt switch 	<ul style="list-style-type: none"> ○Comfortable + safety belt switch ○Seat with armrest with safety belt switch 	<ul style="list-style-type: none"> ○Comfortable + safety belt switch ○Seat with armrest with safety belt switch
Attachments	<ul style="list-style-type: none"> ○Built-in sideshifter ○External shifter ○Fork positioner with sideshift ○Clamp 	<ul style="list-style-type: none"> ○Built-in sideshifter ○External shifter ○Fork positioner with sideshift ○Clamp 	<ul style="list-style-type: none"> ○Built-in sideshifter ○External shifter ○Fork positioner with sideshift ○Clamp 	<ul style="list-style-type: none"> ○Built-in sideshifter ○External shifter ○Fork positioner with sideshift ○Clamp
clamp interlock	<ul style="list-style-type: none"> ●No ○Yes and not customized 	<ul style="list-style-type: none"> ●No ○Yes and not customized 	<ul style="list-style-type: none"> ●No ○Yes and not customized 	<ul style="list-style-type: none"> ●No ○Yes and not customized
Traction pin	<ul style="list-style-type: none"> ●Yes and not customized 	<ul style="list-style-type: none"> ●Yes and not customized 	<ul style="list-style-type: none"> ●Yes and not customized 	<ul style="list-style-type: none"> ●Yes and not customized
Electrostatic discharge chain	<ul style="list-style-type: none"> ●Yes and not customized 	<ul style="list-style-type: none"> ●Yes and not customized 	<ul style="list-style-type: none"> ●Yes and not customized 	<ul style="list-style-type: none"> ●Yes and not customized
Front lamp	<ul style="list-style-type: none"> ●LED 	<ul style="list-style-type: none"> ●LED 	<ul style="list-style-type: none"> ●LED 	<ul style="list-style-type: none"> ●LED
Rear lamp	<ul style="list-style-type: none"> ●No ○LED 	<ul style="list-style-type: none"> ●No ○LED 	<ul style="list-style-type: none"> ●No ○LED 	<ul style="list-style-type: none"> ●No ○LED
Warning lamp	<ul style="list-style-type: none"> ●Yes and not customized 	<ul style="list-style-type: none"> ●Yes and not customized 	<ul style="list-style-type: none"> ●Yes and not customized 	<ul style="list-style-type: none"> ●Yes and not customized
Turn signal light	<ul style="list-style-type: none"> ●LED 	<ul style="list-style-type: none"> ●LED 	<ul style="list-style-type: none"> ●LED 	<ul style="list-style-type: none"> ●LED
Blue lamp	<ul style="list-style-type: none"> ●No ○Rear ○Front and rear 	<ul style="list-style-type: none"> ●No ○Rear ○Front and rear 	<ul style="list-style-type: none"> ●No ○Rear ○Front and rear 	<ul style="list-style-type: none"> ●No ○Rear ○Front and rear
Area warning lamp	<ul style="list-style-type: none"> ●No ○Both sides ○Both side and rear 	<ul style="list-style-type: none"> ●No ○Both sides ○Both side and rear 	<ul style="list-style-type: none"> ●No ○Both sides ○Both side and rear 	<ul style="list-style-type: none"> ●No ○Both sides ○Both side and rear
Rearview mirror	<ul style="list-style-type: none"> ●One on the front ○Two on sides ○Two on sides and one on the front 	<ul style="list-style-type: none"> ●One on the front ○Two on sides ○Two on sides and one on the front 	<ul style="list-style-type: none"> ●One on the front ○Two on sides ○Two on sides and one on the front 	<ul style="list-style-type: none"> ●One on the front ○Two on sides ○Two on sides and one on the front
Buzzer	<ul style="list-style-type: none"> ●Yes and not customized 	<ul style="list-style-type: none"> ●Yes and not customized 	<ul style="list-style-type: none"> ●Yes and not customized 	<ul style="list-style-type: none"> ●Yes and not customized
OPS system	<ul style="list-style-type: none"> ●Yes and not customized 	<ul style="list-style-type: none"> ●Yes and not customized 	<ul style="list-style-type: none"> ●Yes and not customized 	<ul style="list-style-type: none"> ●Yes and not customized
USB interface	<ul style="list-style-type: none"> ●Yes and not customized 	<ul style="list-style-type: none"> ●Yes and not customized 	<ul style="list-style-type: none"> ●Yes and not customized 	<ul style="list-style-type: none"> ●Yes and not customized
Telematics	<ul style="list-style-type: none"> ●Yes and not customized ○No 	<ul style="list-style-type: none"> ●Yes and not customized ○No 	<ul style="list-style-type: none"> ●Yes and not customized ○No 	<ul style="list-style-type: none"> ●Yes and not customized ○No
Turn speed control	<ul style="list-style-type: none"> ●No ○Yes and not customized 	<ul style="list-style-type: none"> ●No 	<ul style="list-style-type: none"> ●No 	<ul style="list-style-type: none"> ●No
Heating system for lithium battery charging	<ul style="list-style-type: none"> ●No ○Yes and not customized 	<ul style="list-style-type: none"> ●No ○Yes and not customized 	<ul style="list-style-type: none"> ●No ○Yes and not customized 	<ul style="list-style-type: none"> ●No ○Yes and not customized
Operator identification device	<ul style="list-style-type: none"> ●No ○Card reader ○Fingerprint lock ○Card reader with keypad 	<ul style="list-style-type: none"> ●No ○Card reader ○Fingerprint lock ○Card reader with keypad 	<ul style="list-style-type: none"> ●No ○Card reader ○Fingerprint lock ○Card reader with keypad 	<ul style="list-style-type: none"> ●No ○Card reader ○Fingerprint lock ○Card reader with keypad
Lifting electronic limit	<ul style="list-style-type: none"> ●No ○Yes and not customized 	<ul style="list-style-type: none"> ●No ○Yes and not customized 	<ul style="list-style-type: none"> ●No ○Yes and not customized 	<ul style="list-style-type: none"> ●No ○Yes and not customized
Hydraulic control	<ul style="list-style-type: none"> ●Mechanical lever ○Joystick ○Fingertip 	<ul style="list-style-type: none"> ●Mechanical lever 	<ul style="list-style-type: none"> ●Mechanical lever 	<ul style="list-style-type: none"> ●Mechanical lever
Rear armrest horn	<ul style="list-style-type: none"> ●Yes and not customized 	<ul style="list-style-type: none"> ●Yes and not customized 	<ul style="list-style-type: none"> ●Yes and not customized 	<ul style="list-style-type: none"> ●Yes and not customized
Cabin	<ul style="list-style-type: none"> ●No ○Basic half cabin ○Upgrade half cabin ○Full cabin 	<ul style="list-style-type: none"> ●No ○Basic half cabin ○Upgrade half cabin ○Full cabin 	<ul style="list-style-type: none"> ●No ○Basic half cabin ○Upgrade half cabin ○Full cabin 	<ul style="list-style-type: none"> ●No ○Basic half cabin ○Upgrade half cabin ○Full cabin
Overhead guard	<ul style="list-style-type: none"> ●With tempered glass ○No 	<ul style="list-style-type: none"> ●With tempered glass ○No 	<ul style="list-style-type: none"> ●With tempered glass ○No 	<ul style="list-style-type: none"> ●With tempered glass ○No

Note: ●Standard ○ Optional - Inconformity