

MAX-8

V2501.02



EP
Let's grow together

MAX-8

Excellent Performances & Reliability

CPD25F8

Four-wheel Electric Forklift 2.5t

Continuous 8-hour Operation
Charging-free for Heavy-duty Shift.

EP EQUIPMENT CO.,LTD
www.ep-equipment.com

Four-wheel Electric Forklift 2.5t

CPD25F8

Distinguishing mark				
1.1	Manufacturer			EP
1.2	Model designation			CPD25F8
1.3	Drive unit			Electrics
1.4	Operator type			seated
1.5	rated capacity	Q	kg	2500
1.6	Load center distance	c	mm	500
1.8	Load distance, centre of drive axle to fork	x	mm	456
1.9	Wheelbase	y	mm	1500
Weight				
2.1	Service weight		kg	4030
2.2	Axle loading, laden front/ rear		kg	5930/600
2.3	Axle loading, unladen front/ rear		kg	1800/2230
Tyre, type				
3.1	Tyre type			pneumatic
3.2	Tyre size, front			23×9-10
3.3	Tyre size, rear			18X7-8
3.5	Wheels, number front/ rear (x=drive wheels)		mm	2x/ 2
3.6	Tread, front	b ₁₀	mm	1045
3.7	Tread, rear	b ₁₁	mm	950
Dimensions				
4.1	Tilt of mast/fork carriage forward/backward	α/β (°)		6/11
4.2	Height, mast lowered	h ₁	mm	1985
4.3	Free lift	h ₂	mm	120
4.4	Lift height	h ₃	mm	3000
4.5	Height, mast extended	h ₄	mm	4010
4.7	Height of overhead guard (cabin)	h ₆	mm	2180
4.8	Seat height/standing height	h ₇	mm	1105
4.12	Tow coupling height	h ₁₀	mm	305
4.19	Overall length	l ₁	mm	3416
4.20	Length to face of forks	l ₂	mm	2346
4.21	Overall width	b ₁ /b ₂	mm	1252
4.22	Fork dimensions	s/e/l	mm	40×120×1070
4.23	Fork carriage class/type A, B			2A
4.24	Fork carriage width	b ₃	mm	1085
4.31	Ground clearance, laden, below mast	m ₁	mm	110
4.32	Ground clearance, center of wheelbase	m ₂	mm	125
4.34.1	Aisle width for pallets 1000 × 1200 crossways	A _{st}	mm	3791
4.34.2	Aisle width for pallets 800 × 1200 crossways	A _{st}	mm	3991
4.35	turning radius	W _a	mm	2135
Performance data				
5.1	Travel speed, laden/ unladen		km/ h	13/ 13.5
5.2	Lifting speed, laden/ unladen		m/ s	0.3/ 0.45
5.3	Lowering speed, laden/ unladen		m/ s	0.44/ 0.435
5.5	Drawbar pull, laden/unladen		N	—
5.6	Max. drawbar pull, laden/unladen		N	17000
5.7	Gradeability, laden/unladen		%	—
5.8	Max. gradeability, laden/unladen		%	10.5/14
5.9	Acceleration time, laden/unladen		s	Hydraulic+Mechanical
5.10	Service brake			Mechanical
Electric-engine				
6.1	Drive motor rating S2 60 min		kW	11
6.2	Lift motor rating at S3 15%		kW	13
6.3	Battery according to DIN 43531 /35 / 36 A, B, C, no			—
6.4	Battery voltage/nominal capacity K5		V/Ah	48/630(Max770)
6.5	Battery weight		kg	1044
Addition data				
8.1	Type of drive unit			AC
10.5	Steering type			—
10.7	Sound pressure level at the driver's ear		dB (A)	71

If there are improvements of technical parameters or configurations, no further notice will be given. The diagram shown may contain non-standard configurations.

Mast Option

CPD25F8

Type	Model	Max. fork height h3	Overall height				Free lift		Front Overhang X		Tilt range		Capacity	
			Lowered h1	Extended		Without backrest	With backrest h2	FWD α			BWD β	Load capacity at 500 mm		
				Without backrest	With backrest h4				Single tire					
			mm	mm	mm	mm	mm	mm	mm	mm	Deg	Deg	2.0t	2.5t
Wide view mast	2W200	2000	1485	2685	3010	120	120	456	456	6	11	2000	2500	
	2W250	2500	1735	3185	3510	120	120	456	456	6	11	2000	2500	
	2W270	2700	1835	3385	3710	120	120	456	456	6	11	2000	2500	
	2W300	3000	1985	3685	4010	120	120	456	456	6	11	2000	2500	
	2W330	3300	2135	3985	4310	120	120	456	456	6	11	2000	2500	
	2W350	3500	2235	4185	4510	120	120	456	456	6	11	2000	2500	
	2W360	3600	2285	4285	4610	120	120	456	456	6	11	2000	2500	
	2W400	4000	2535	4685	5010	120	120	456	456	6	11	1900	2300	
	2W430	4300	2685	4985	5310	120	120	456	456	6	6	1800	2100	
2W450	4500	2785	5185	5510	120	120	456	456	6	6	1700	2000		
wide view full 2-stage mast	2F250	2500	1770	3205	3510	1065	760	456	456	6	11	2000	2500	
	2F270	2700	1870	3405	3710	1165	860	456	456	6	11	2000	2500	
	2F300	3000	2030	3705	4010	1325	1020	456	456	6	11	2000	2500	
	2F330	3300	2170	4005	4310	1465	1160	456	456	6	11	2000	2500	
	2F360	3600	2330	4305	4610	1625	1320	456	456	6	11	2000	2500	
	2F400	4000	2580	4705	5010	1875	1570	456	456	6	11	1900	2300	
wide view full 3-stage mast	3F430	4300	2020	5000	5310	1320	1010	456	456	6	6	1700	2000	
	3F450	4500	2100	5200	5510	1400	1090	500	500	6	6	1600	1900	
	3F480	4800	2205	5500	5810	1505	1195	500	500	6	6	1500	1700	
	3F500	5000	2290	5700	6010	1590	1280	500	500	6	6	1400	1600	
	3F550	5500	2540	6200	6510	1840	1530	500	500	3	6	1050	1200	
	3F600	6000	2790	6700	7010	2090	1780	500	500	3	6	700	800	

CPD25F8
RATED CAPACITIES GRAPH

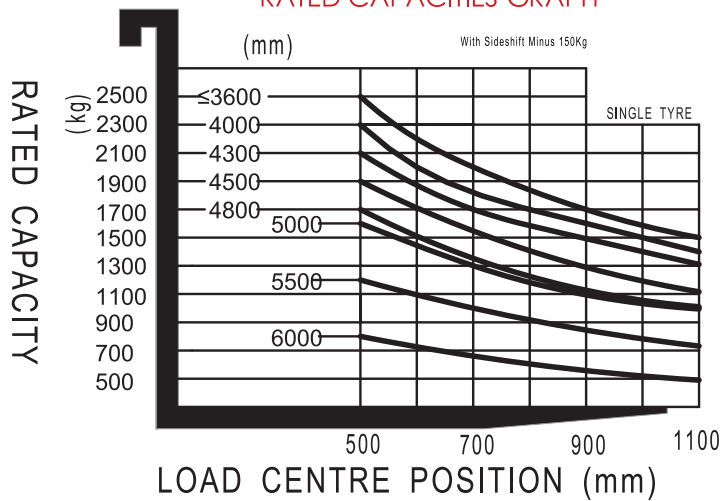

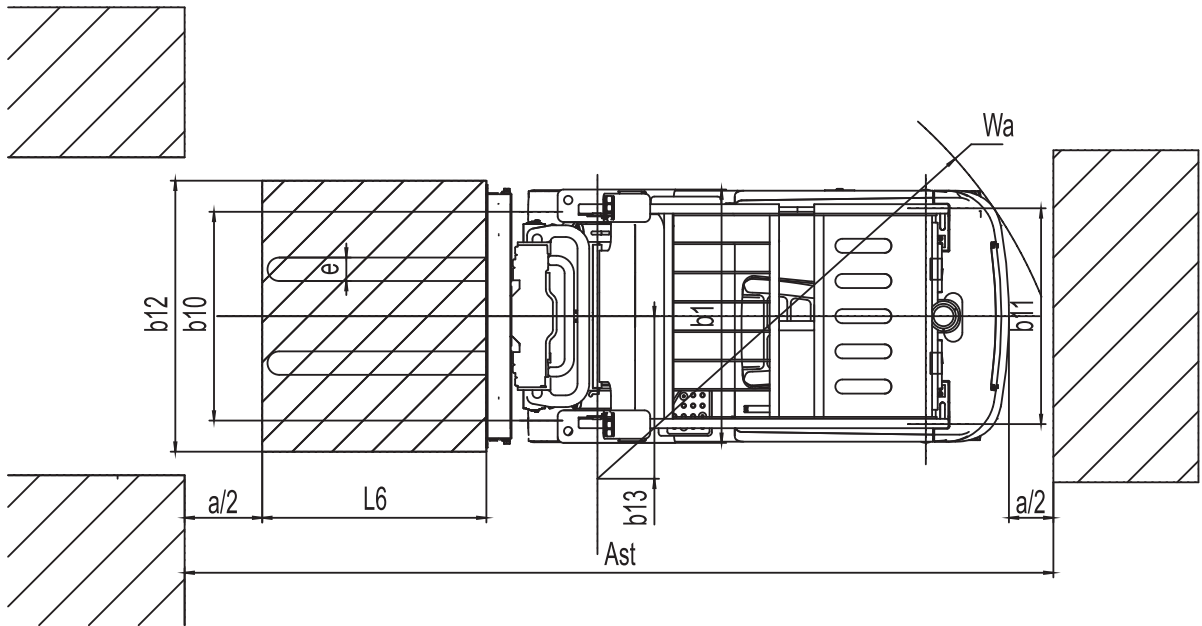
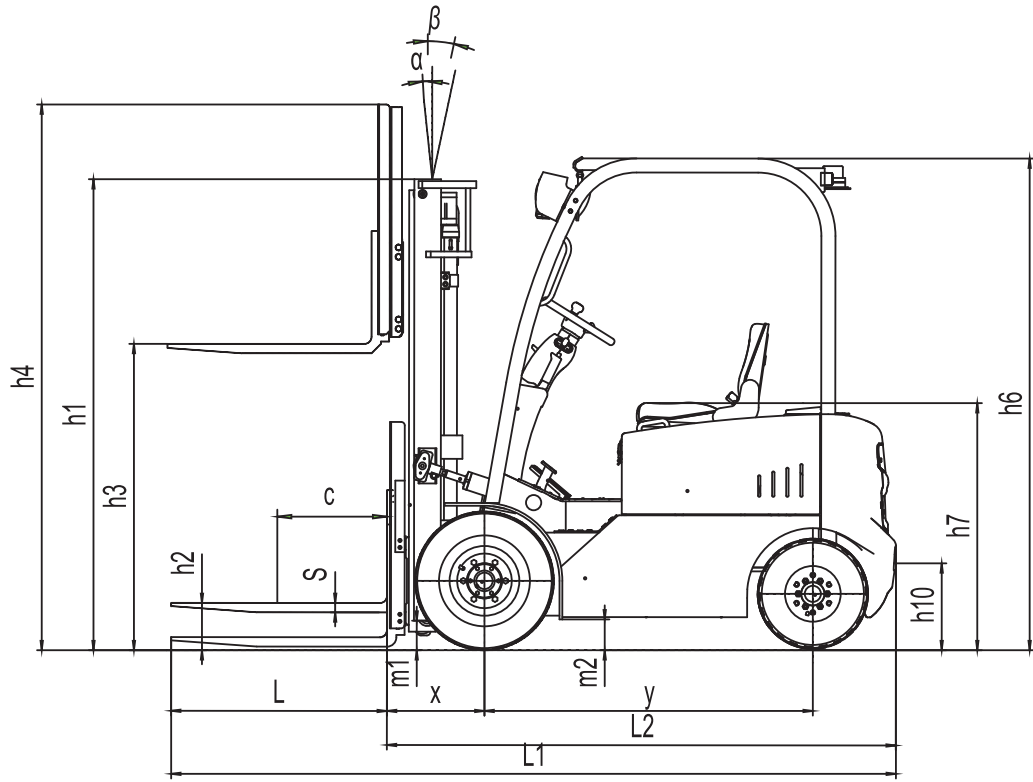



Option

Options			CPD25F8
1	Fork length		○
2	Fold fork		—
3	Battery capacity		○
4	Import battery		○
5	Solid rubber tire		○
6	Environmental solid tire		○
7	Cold storage		○
8	Lateral change battery		○
9	fork weighing system		○
10	Overhead guard		○
11	Mast options		○
12	Attachments		○
13	Built in side shift		○
14	Proportional valve		—
17		LED front light	●
28	Light	Back light	○
22		Warning light	●
18	Fire extinguisher		○
19	Water auto-fillingsystem		○
20	Seat		○
21	Seat switch		○
23		With fan heater	○
25	Cockpit	With front windshield wiper	○
26		With rear windshield wiper	○
16		Cockpit	○
24	Double front wheel		—
27	Rearview		○
29	OPS system		○
30	Backrest width		○
31	Environmental solid tire		○
32	Air fan		○
33	Charging voltage		○
35	Drive-in Rack		○

Note: ● standard ○ option — NA