

**EP**  
Let's grow together

# EFL252X3

## 2500kg Li-ion Counterbalance Forklift



- High ground clearance and big tyres to operate on uneven surfaces
- PMSM technology for better efficiency and performance
- Removable Li-ion battery fitting multi-shift operation better
- All-rounder both for indoor and outdoor usage
- Ergonomic zone for fatigue-free work
- 80V Li-Ion battery grant efficiency, good autonomy and opportunity charging
- Single phase integrated charger with 16A plug



Manufacturer			EP
Model designation			EFL252X3
Drive			Electric
Load capacity	Q	kg	2500
Load center distance	c	mm	500
Service weight		kg	4255
Retracted mast height	h1	mm	2090
Lift height	h3	mm	3000
Height, mast extended	h4	mm	4025
Length to face of forks	l2	mm	2550
Overall width	b1/b2	mm	1154
Turning radius	s/e/l	mm	2250
Travel speed, laden/unladen	Wa	km/h	11/12
Lifting speed, laden/unladen		m/s	0.29/0.36
Lowering speed, laden/unladen		m/s	0.4/0.43
Max. gradeability, laden/unladen		%	15/15
Drive motor rating S2 60 min		kW	8
Battery voltage/nominal capacity		V/Ah	80/150

## FEATURE

### ■ PMSM technology for better efficiency and performance

The EFL252X3 adopts permanent magnet synchronous motor (PMSM) technology to deliver longer battery life. This efficiency optimization motor brings better energy savings and maximizes the battery uptime at optimal working scenarios by 10% comparing to regular motors.



PMSM



Longer  
uptime



Energy  
saving



### ■ Removable Li-ion battery offering convenience for daily usage

The EFL252X3 is designed around the advantages of lithium technology, equipped with removable 80V/150Ah Li-ion battery as standard. It allows for not only opportunity charging and zero maintenance, but also being laterally pulled and replaced easily, which makes it a helper for rugged environments that lack of charging facilities.



## ■ All-rounder for both indoor and outdoor usage

The compact EFL252X3 features a small turning radius 2250mm, and its agility ensures handling capacities in tight spaces and narrow aisles. Besides, the EFL252X3 is water-protected and can be operated outdoors, even in the rain.



## ■ Ergonomic zone for fatigue-free work

The EFL252X3 comes offers a spacious workspace, with a simplified panel, an adjustable steering wheel and a comfortable pedal. All are designed in line with ergonomic considerations for operation comfort.



# 2.5ton Li-ion Counterbalance Forklift Truck

## EFL252X3

Distinguishing mark	1.1	Manufacturer			EP
	1.2	Model designation			EFL252X3
	1.3	Drive			Electric
	1.4	Operator type			Seated
	1.5	Load capacity	Q	kg	2500
	1.6	Load center distance	c	mm	500
	1.8	Load distance, centre of drive axle to fork	x	mm	495
	1.9	Wheelbase	y	mm	1650
	Service weight	2.1	Service weight		kg
2.2		Axle loading, laden front/rear		kg	5815/940
2.3		Axle loading, unladen front/rear		kg	1805/2450
Tyres/chassis	3.1	Tyre type			Solid rubber
	3.2	Tyre size, front			7.00-12
	3.3	Tyre size, rear			18X7-8
	3.5	Wheels, number front/rear (x=drive wheels)		mm	2x/ 2
	3.6	Tread width, front	b10	mm	975
	3.7	Tread width, rear	b11	mm	955
	Dimensions	4.1	Tilt of mast/fork carriage forward/backward	$\alpha/\beta$	°
4.2		Retracted mast height	h1	mm	2090
4.3		Free lift	h2	mm	135
4.4		Lift height	h3	mm	3000
4.5		Height, mast extended	h4	mm	4025
4.7		Height of overhead guard (cabin)	h6	mm	2170
4.8		Seat height/standing height	h7	mm	1110
4.12		Tow coupling height	h10	mm	295
4.19		Overall length	l1	mm	3620
4.20		Length to face of forks	l2	mm	2550
4.21		Overall width	b1/b2	mm	1154
4.22		Fork dimensions	s/e/l	mm	40×122×1070
4.23		A,B Fork carriage class/type A, B			2A
4.24		Fork carriage width	b3	mm	1040
4.31		Ground clearance, laden, below mast	m1	mm	120
4.32		Ground clearance, center of wheelbase	m2	mm	150
4.34.1		Aisle width for pallets 1000×1200 crossways	Ast	mm	3945
4.34.2		Aisle width for pallets 800×1200 crossways	Ast	mm	4145
4.35		Turning radius	Wa	mm	2250
Performance data		5.1	Travel speed, laden/unladen		km/h
	5.2	Lifting speed, laden/unladen		m/s	0.29/0.36
	5.3	Lowering speed, laden/unladen		m/s	0.4/0.43
	5.5	Drawbar pull, laden/unladen		N	—
	5.6	Max. drawbar pull, laden/unladen		N	—
	5.8	Max. gradeability, laden/unladen		%	15/15
	5.10	Service brake			Hydraulic
	5.11	Parking brake			Mechanical
Electric-engine	6.1	Drive motor rating S2 60 min		kW	8
	6.2	Lift motor rating at S3 15%		kW	16
	6.4	Battery voltage/nominal capacity		V/Ah	80V150AH
	6.5	Battery weight		kg	—
Addition data	8.1	Type of drive control			—
	10.5	Steering design			Hydraulic
	10.7	Sound pressure level at the driver's ear		dB(A)	< 74

If there are improvements of technical parameters or configurations, no further notice will be given.  
The diagram shown may contain non-standard configurations.

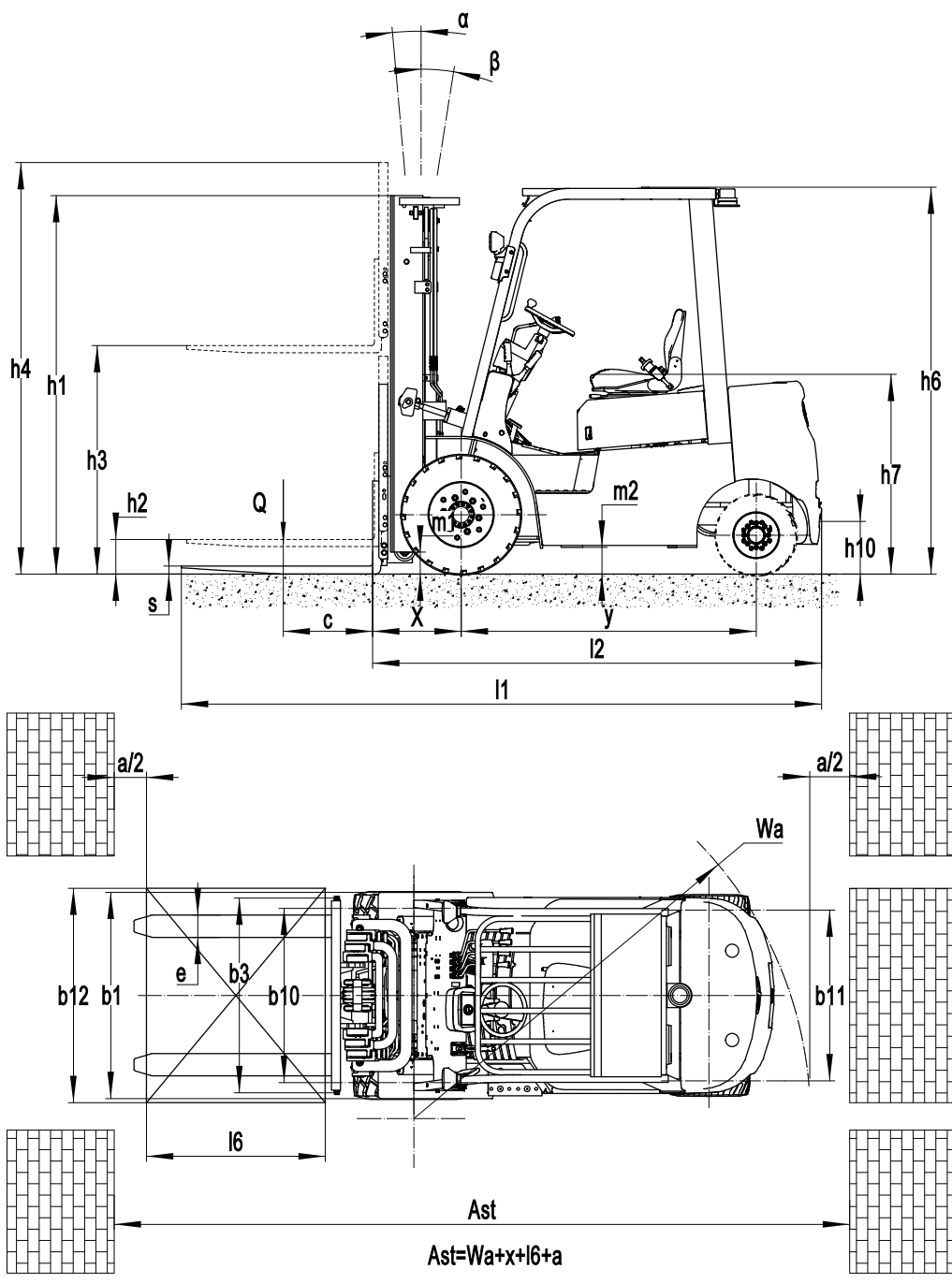

**RATED CAPACITIES AND LOAD CENTERS GRAPH**

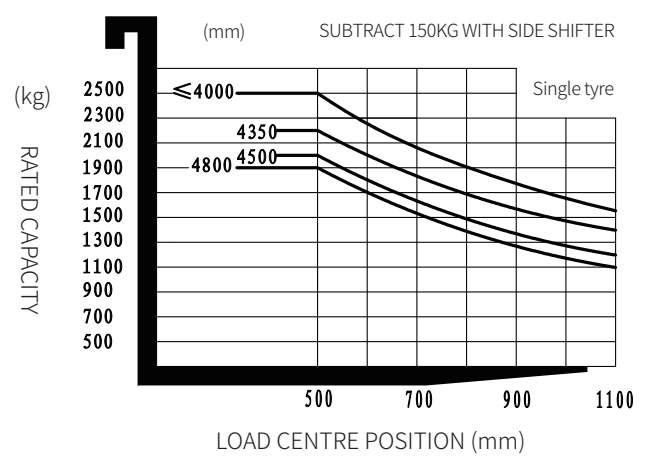

# Mast Option

Mast types	Lift height (h3)	Height, Mast			Height, Free lift(h2)	
		Height, mast lowered(h1)	Height, mast extended(h4)		No shelving	With shelving
	No shelving		With shelving	mm		
2-Standard Mast	3000	2090	3565	4025	120	120
	3300	2240	3865	4325	120	120
3-Free Mast	4500	2115	5065	5525	1550	1090
	4800	2220	5365	5825	1655	1195

# Option

Optional items	EFL252X3
Fork dimension	<ul style="list-style-type: none"> <li>○122*40*920●122*40*1070○122*40*1150○122*40*1220○122*40*1370</li> <li>○122*40*1500○122*40*1600○122*40*1700○122*40*1820○122*40*1900</li> <li>○122*40*2000○122*40*2200</li> </ul>
Fork carriage width	●1040mm○Yes and not customized
Backrest height	●1025mm○Yes and not customized
Front wheel material	●Pneumatic○Normal solid○Traceless solid
Rear wheel material	●Pneumatic○Normal solid○Traceless solid
Battery capacity	●80V100AH○80V150AH○80V230AH
Charger	<ul style="list-style-type: none"> <li>○80V65A (External) ●80V35A(Interior) ○80V60A(Interior)</li> <li>○80V100A (External, only for 80V230AH battery)</li> </ul>
Battery indicator	●With hourmeter
Seat type	<ul style="list-style-type: none"> <li>○Comfortable●Suspension</li> <li>○Suspension + safety belt logic switch○comfortable + safety belt logic switch</li> </ul>
Attachments	●No○Built-in sidershifter○External shifter
Traction pin	●Yes and not customized
Anti-static chain	●Yes and not customized
Front lamp	●LED
Rear lamp	●No○LED
Warning lamp	●Yes and not customized
Turn signal light	●LED
Blue lamp	●None○The first one+ the last one○The latter one○The first two + the last one
Area warning lamp	●None○Red, one on each side○One on each side + one on the back
Rearview mirror	●A rearview mirror○Double rearview mirror
Buzzer	●Yes and not customized
OPS system	●Yes and not customized○No
USB interface	●Yes and not customized
Telematics	●Yes and not customized○No
Fan heater	●No○Yes and not customized
Speed reduction for elevated mast- Australian standard	●No○Yes and customized
Cabin	<ul style="list-style-type: none"> <li>●None○Semi-enclosed cockpit</li> <li>○Fully enclosed cockpit with electric fan, heater, front wipers, rear wipers</li> </ul>
Proportional lift system	●Yes and not customized
Overhead guard	●Standard overhead guard○Yes and customizable
Note:	●Standard ○ Optional - Inconformity