



EPT20-ET2L

Li-ion Pedestrian Pallet Truck 2.0T

- Robust and compact truck for various sectors
- Easy and safe operation
- Lithium technology with integrated charger
- User-centered design

LI-ION
TECHNOLOGY

EP EQUIPMENT CO.,LTD
www.ep-ep.com

▣ FEATURE



■ Robust and compact truck for various sectors

EPT20-ET2L demonstrates robust iron cover and compact chassis, delivering both endurance and agility. This makes it able to cope with rugged and narrow environments.

■ Lithium technology with integrated charger

EPT20-ET2L features the 48V/20Ah Li-ion battery and the 48V/10A integrated charger as standard, which makes it a workhorse in multi-shift applications thanks to ease of charging. AGM version is also available as an option to meet different needs.

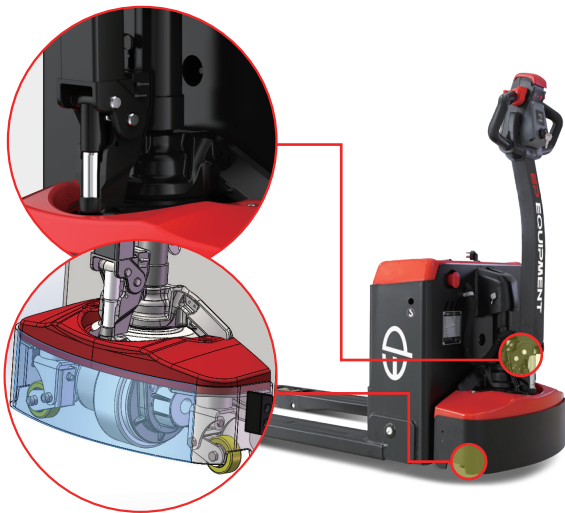

■ Easy and safe operation

EPT20-ET2L adopts a mechanical rebound spring and castor wheels as standard so that the truck can be operated more easily and safety.

■ User-centered design

EPT20-ET2L features a metal cover with safety assurance and storage space for daily convenience. It is also easy for diagnosis and maintenance thanks to the good layout of electronic components.

Li-ion Pedestrian Pallet Truck 2.0T

EPT20-ET2L

Distinguishing mark	1.1	Manufacturer			EP
	1.2	Model designation			EPT20-ET2L
	1.3	Drive			Electric
	1.4	Operator type			Pedestrian
	1.5	Load capacity	Q	kg	2000
	1.6	Load center distance	c	mm	600
	1.8	Load distance, centre of drive axle to fork	x	mm	891/954
	1.9	Wheelbase	y	mm	1201/1264
	Service weight	2.1	Service weight		kg
2.2		Axle loading, laden front/rear		kg	670/1526
2.3		Axle loading, unladen front/rear		kg	110/86
Tyres/chassis	3.1	Tyre type			Polyurethane
	3.2.1	Tyre size, front		mm	Φ210x70
	3.3.1	Tyre size, rear		mm	2x Φ80x61(Φ74x88)
	3.4	Additional wheels (castor wheels)		mm	Φ74x30
	3.5	Wheels, number front/rear (x=drive wheels)		mm	1x 2/4
	3.6.1	Tread width, front	b10	mm	438 / -
	3.7.1	Tread width, rear	b11	mm	410 (535)
Dimensions	4.4	Lift height	h3	mm	115
	4.9	Height of tiller handle in drive position min./max.	h14	mm	750/1170
	4.15	Lowered height	h13	mm	80
	4.19	Overall length	l1	mm	1626
	4.20	Length to face of forks	l2	mm	476
	4.21	Overall width	b1/b2	mm	680
	4.22	Fork dimensions	s/e/l	mm	50/150/1150
	4.25	Distance between fork-arms	b5	mm	560 (685)
	4.32	Ground clearance, center of wheelbase	m2	mm	30
	4.34.1	Aisle width for pallets 1000×1200 crossways	Ast	mm	2217
	4.34.2	Aisle width for pallets 800×1200 lengthways	Ast	mm	2279
4.35	Turning radius	Wa	mm	1460	
Performance data	5.1	Travel speed, laden/unladen		km/h	5/5.5
	5.2	Lifting speed, laden/unladen		m/s	0.017/0.021
	5.3	Lowering speed, laden/unladen		m/s	0.05/0.026
	5.8	Max. gradeability, laden/unladen		%	8/16
	5.10	Service brake			Electromagnetic
Electric-engine	6.1	Drive motor rating S2 60 min		kW	0.9
	6.2	Lift motor rating at S3 15%		kW	0.84
	6.4	Battery voltage/nominal capacity		V/Ah	48V/20Ah
	6.5	Battery weight		kg	12
	Addition data	8.1	Type of drive control		
10.5		Steering design			Mechanical
10.7		Sound pressure level at the driver's ear		dB(A)	74

If there are improvements of technical parameters or configurations, no further notice will be given.
The diagram shown may contain non-standard configurations.

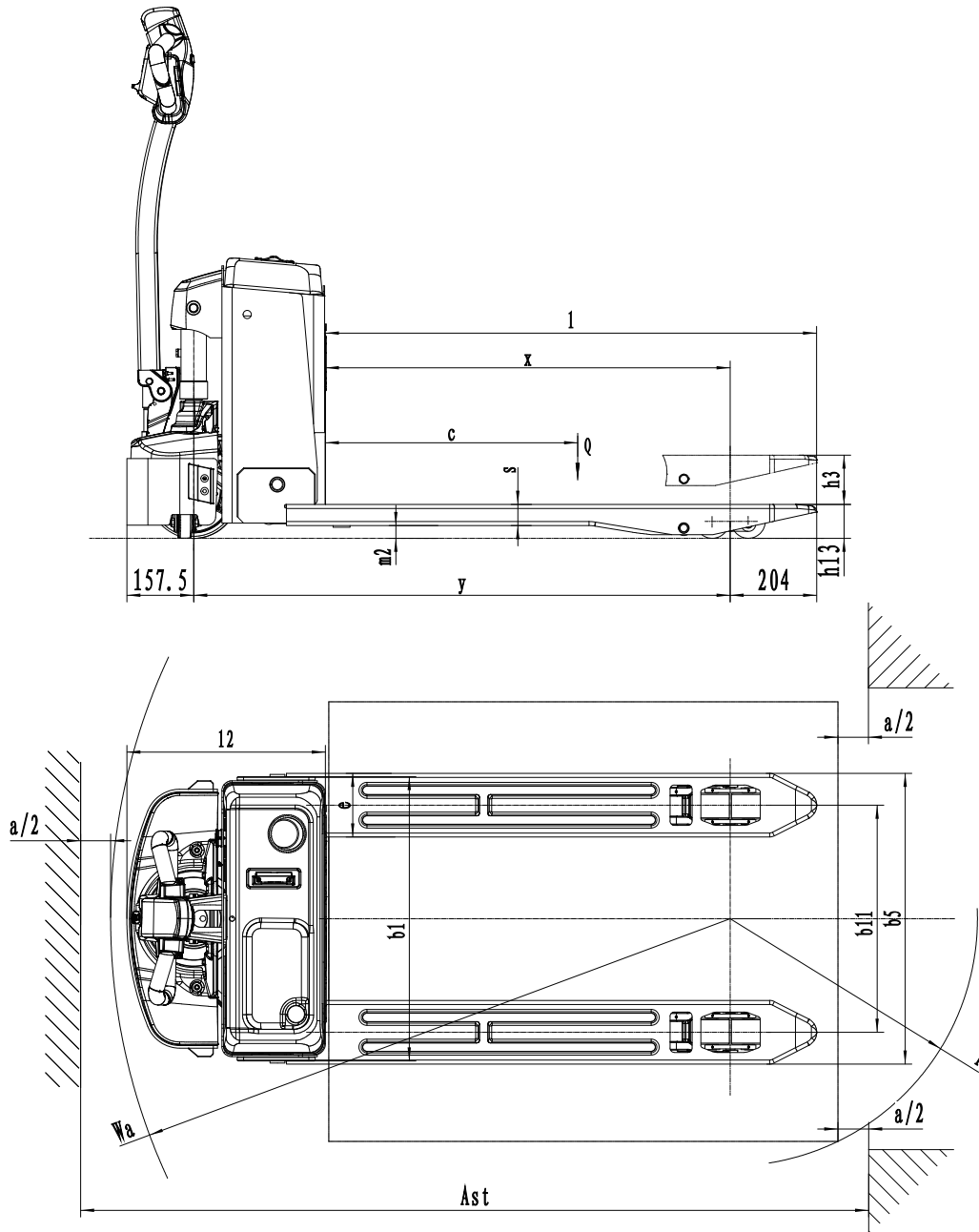

Option

No.	Optional items	EPT20-ET2L
1.1	Fork length	●1150 ○1220 ○800 ○850 ○900 ○915 ○950 ○980 ○1000 ○1070 ○1100 ○1300 ○1350 ○1400 ○1450
1.2	Fork width	●560○685
1.3	Fork lowered height	●80
2.1	Load wheel type	●Double○Single
2.2	Load wheel material	●PU
2.3	Drive wheel material	●PU
2.7	Battery capacity	●48V*20A Li-ion ○48V*30Ah (AGM) ○48V*45Ah (AGM)
2.8	Charger	●48V-10A integrated (Li-ion) ○48V-5A integrated (30Ah AGM) ○48V-7A integrated (45Ah AGM)
2.9	Battery indicator	●Yes and not customized
3.3	Castor wheels	●Yes (ground clearance of the foot guard 60mm) ○Yes (ground clearance of the foot guard 30mm) ○No
3.16	Vertical handler working	●Yes and not customized

Note: ●Standard ○ Optional - Inconformity