



F Series - F2

Electric Pallet Truck 1.5T

- A smart and sleek truck for retail usage
- Sleek truck frame and lithium technology
- Upgraded load capacity offering greater productivity
- New tiller head for ergonomics
- Unique Platform F design reducing costs throughout the distribution cycle

LIION
TECHNOLOGY

EP EQUIPMENT CO.,LTD
www.ep-ep.com



F2 - A smart and sleek truck for retail usage

■ Sleek truck frame and lithium technology

F2 is born from the market-proven model EPT12-EZ and carries its strengths on both appearance and lithium power supply. Its sleek truck frame is perfect for handling usage in supermarkets and malls. And the smart Li-ion battery makes F2 always available for retail usage due to opportunity charging and maintenance free.



■ Upgraded load capacity offering greater productivity

F2 comes with 120kg self weight but higher load capacity 1.5 ton than EPT12-EZ, offering greater productivity boost.



■ New tiller head for ergonomics

F2 adopts a new tiller head for an user to operate the truck more easily using the palm of his hand, instead of controlling the knob with thumbs. The pinch force exerted on a control knob during operations can be minimized so that excessive physical stress and strain on the hands are reduced.



Why F Series ?

■ Platform-based design to maximize competitive advantage in the market

F series features the platform F, which simplifies the configuration of the truck and allows buyers to choose from 4 different chassis by application. The product design provides value and creates a flexible product strategy by introducing new equipment that meets various market requirements.



■ Cost-saving operations throughout the distribution cycle

4 units per box as standard wholesale supply reduces overall spending through the entire distribution process. F2 accommodates **176** units in a 40' shipping container compared to 108 units of EPT12-EZ, that can reach as high as **30-40%** of ocean freight charges reduction.

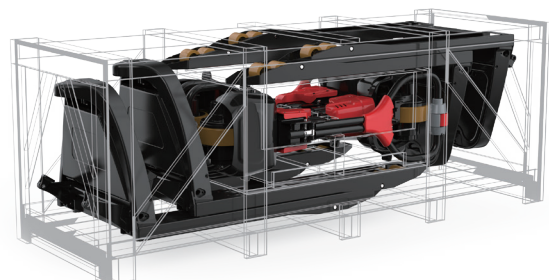

Electric Pallet Truck 1.5T

F2

Distinguishing mark	1.1	Manufacturer			EP
	1.2	Model designation			F2
	1.3	Drive			Electric
	1.4	Operator type			Pedestrian
	1.5	Load capacity	Q	kg	1500
	1.6	Load center distance	c	mm	600
	1.8	Load distance, centre of drive axle to fork	x	mm	950
	1.9	Wheelbase	y	mm	1180
	Service weight	2.1	Service weight		kg
2.2		Axle loading, laden front/rear		kg	480/1140
2.3		Axle loading, unladen front/rear		kg	90/30
Tyres/chassis	3.1	Tyre type			Polyurethane
	3.2.1	Tyre size, front		mm	210x70
	3.3.1	Tyre size, rear		mm	Φ80x60(Φ74x88)
	3.4	Additional wheels (castor wheels)		mm	Φ74x30 optional
	3.5	Wheels, number front/rear (x=drive wheels)		mm	1x 2/4 (1x 2/2)
	3.6.1	Tread width, front	b10	mm	—
	3.7.1	Tread width, rear	b11	mm	535/410
Dimensions	4.4	Lift height	h3	mm	105
	4.9	Height of tiller handle in drive position min./max.	h14	mm	750/1190
	4.15	Lowered height	h13	mm	82
	4.19	Overall length	l1	mm	1550
	4.20	Length to face of forks	l2	mm	400
	4.21	Overall width	b1/b2	mm	695/590
	4.22	Fork dimensions	s/e/l	mm	55/150/1150
	4.25	Distance between fork-arms	b5	mm	685/560
	4.32	Ground clearance, center of wheelbase	m2	mm	25
	4.34.1	Aisle width for pallets 1000×1200 crossways	Ast	mm	2160
4.34.2	Aisle width for pallets 800×1200 crossways	Ast	mm	2025	
4.35	Turning radius	Wa	mm	1360	
Performance data	5.1	Travel speed, laden/unladen		km/h	4/4.5
	5.2	Lifting speed, laden/unladen		m/s	0.017/0.020
	5.3	Lowering speed, laden/unladen		m/s	0.046/0.058
	5.8	Max. gradeability, laden/unladen		%	5/16
	5.10	Service brake			Electromagnetic
Electric-engine	6.1	Drive motor rating S2 60 min		kW	0.75
	6.2	Lift motor rating at S3 15%		kW	0.5
	6.4	Battery voltage/nominal capacity		V/Ah	24/20
	6.5	Battery weight		kg	5
	Addition data	8.1	Type of drive control		
10.5		Steering design			Mechanical
10.7		Sound pressure level at the driver's ear		dB(A)	<74

If there are improvements of technical parameters or configurations, no further notice will be given.
The diagram shown may contain non-standard configurations.

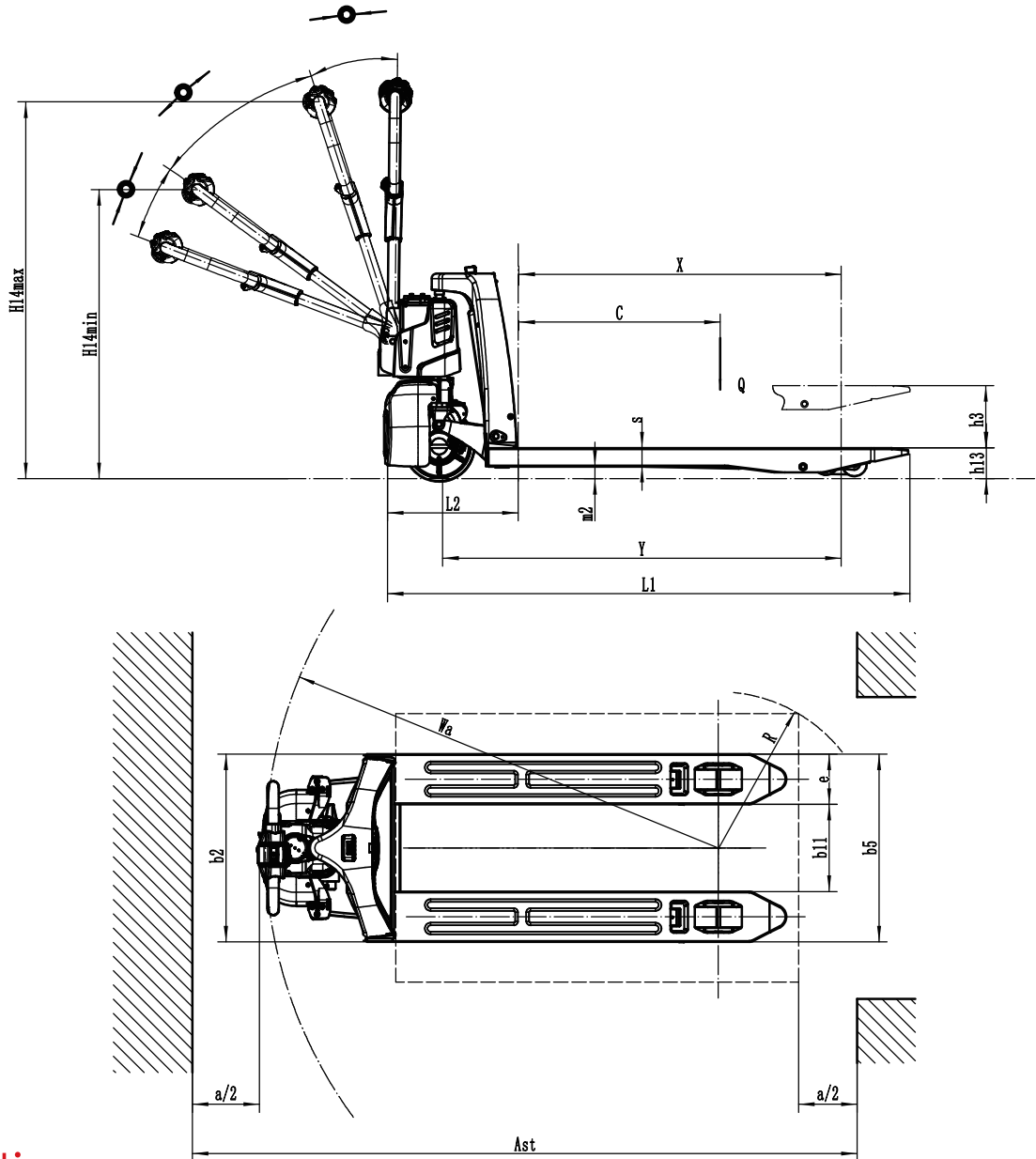

Option:

No.	Optional items	F2
1.1	Fork dimension	<ul style="list-style-type: none"> ●1150*560○900*560○1000*560 ○1220*560○1350*560○1500*560○900*685 ○1000*685○1150*685○1220*685○1350*685○1500*685
1.3	Fork lowered height	●80
1.6	Drive cover off the ground	●45mm (CE)○65mm (Non CE)
2.1	Load wheel type	●Double○Single
2.2	Load wheel material	●Polyurethane
2.3	Drive wheel material	●Polyurethane
2.7	Battery capacity	●20AH×1○20AH×2○20AH×3○20AH×4
2.8	Charger	●24V-4A External○24V-10A External
2.9	Battery indicator	●Without time
2.16	handle head type	●Hands big handle head○Hands small handle head
3.3	Castor wheels	●No○Yes and not customized
3.12	Hummer	●Yes and not customized
3.16	Vertical handler working	●Yes and not customized
4.8	Drive assembly	●Yes and not customized

Note: ●Standard ○ Optional - Inconformity