



RSB141

Electric Stacker 1.4T

- Strong drive power
- Operation safety assurance
- Easy steering

EP EQUIPMENT CO.,LTD
www.ep-ep.com

FEATURE

Strong drive power

RSB141 adopts EP's second generation BLDC motor drive technology to offer strong drive power and save the maintenance trouble of replacing carbon brushes.



Easy steering

The truck is equipped with electronic steering as standard to reduce steering strains and to offer better maneuverability in operation.



Operation safety assurance

RSB141 is proven safety by passing the industrial rollover test. Intelligence auto-break making it a safe helper when working on the slope. The low ground clearance also lowers the risk of foot injuries significantly.



Electric Stacker 1.4T

RSB141

Distinguishing mark				
1.1	Manufacturer			EP
1.2	Model designation			RSB141
1.3	Drive unit			Battery
1.4	Operator type			standing
1.5	rated capacity	Q	kg	1400
1.6	Load center distance	c	mm	600
1.8	Load distance, centre of drive axle to fork	x	mm	690
1.9	Wheelbase	y	mm	1145
Weight				
2.1	Service weight (include battery)		kg	770
2.2	Axle loading, laden driving side/loading side		kg	620/1550
2.3	Axle loading, unladen driving side/loading side		kg	530/240
Types,Chassis				
3.1	Tyre type Driving wheels/Loading wheels			PU/PU
3.2	Tyre size, driving wheels (diameter×width)		mm	Φ230×75
3.3	Tyre size, loading wheels (diameter×width)		mm	Φ85×95
3.4	Tyre size, caster wheels (diameter×width)		mm	Φ130×55
3.5	Wheels, number driving, caster/loading (x=drive wheels)		mm	1x +1/2
3.6	Track width, front,driving side	b10	mm	539
3.7	Track width,rear,loading side	b11	mm	436
Dimensions				
4.2	Height, mast lowered	h1	mm	1970
4.3	Free lift	h2	mm	/
4.4	Lift height	h3	mm	2930
4.5	Height, mast extended	h4	mm	3425
4.9	Height drawbar in driving position min./max.	h14	mm	1150/1480
4.15	Lowered height	h13	mm	85
4.19	Overall length	l1	mm	1754
4.20	Length to face of forks	l2	mm	604
4.21	Overall width	b1	mm	800
4.22	Fork dimensions	s/ e/ l	mm	60×170×1150
4.24	Fork carriage width	b3	mm	750
4.25	Distance between fork-arms	b5	mm	600
4.32	Ground clearance, center of wheelbase	m2	mm	25
4.34.1	Aisle width for pallets 1000 × 1200 crossways	Ast	mm	2130
4.34.2	Aisle width for pallets 800 × 1200 lengthways	Ast	mm	2103
4.35	Turning radius	Wa	mm	1455
Performance data				
5.1	Travel speed, laden/ unladen		km/ h	5/5.5
5.2	Lifting speed, laden/ unladen		m/ s	0.10/0.18
5.3	Lowering speed, laden/ unladen		m/ s	0.29/0.19
5.8	Max. gradeability, laden/unladen		%	3/10
5.10	Service brake type			Electromagnetic
Electric-engine				
6.1	Drive motor rating S2 60 min		kW	0.9
6.2	Lift motor rating at S3 15%		kW	2.2
6.3	The maximum allowed size battery		mm	260×165×210
6.4	Battery voltage/nominal capacity K5		V/ Ah	48/85
6.5	Battery weight		kg	15×4
Addition data				
8.1	Type of drive unit			DC
10.5	Steering type			Electronic
10.7	Sound pressure level at the driver's ear		dB (A)	74

If there are improvements of technical parameters or configurations, no further notice will be given.
The diagram shown may contain non-standard configurations.

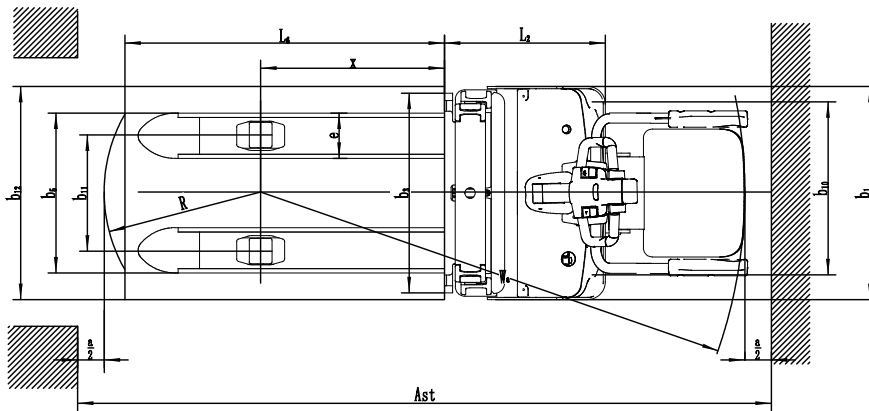
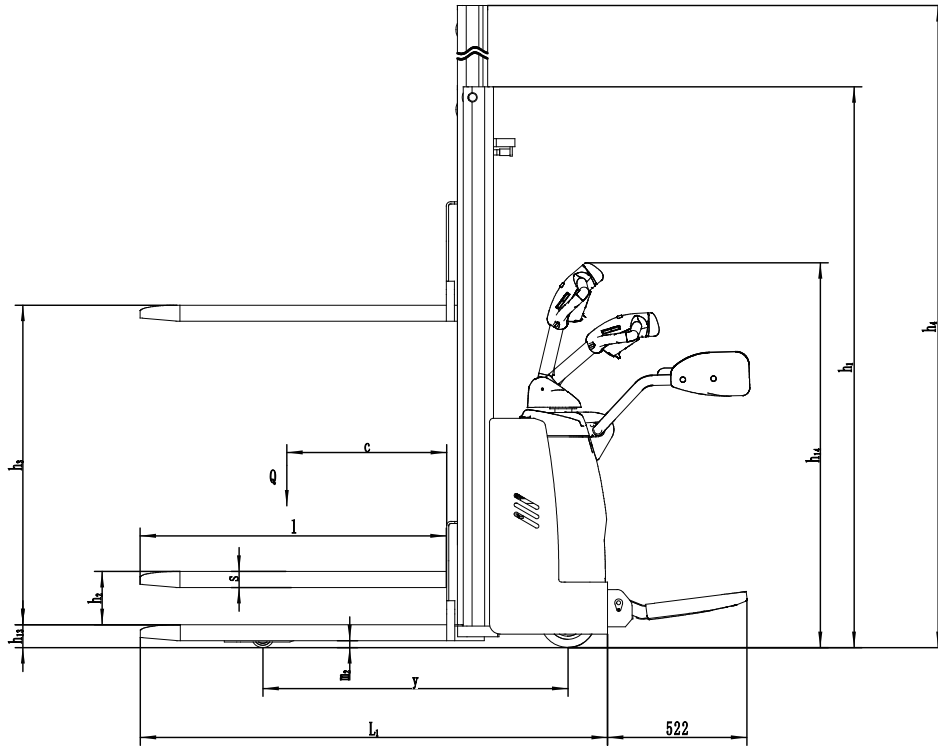

RATED CAPACITIES GRAPH



Mast Option

Mast types	Close Mast height h1	Free height h2	Lift height h3+h13	Extended Mast Height h4
Two Stage Mast (Wide view)	1710	/	2500	2925
	1810	/	2700	3125
	1960	/	3000	3425
	2110	/	3300	3725
	2260	/	3600	4025
	2410	/	3900	4325

Option

Optional items		RSB141
1	Fork length	1150/1220
2	Fork width	685/600/570
9	Single load wheel	●
10	Driving wheel	●
11	Balance wheel	●
15	cold storage	—
17	Battery indicator with hour meter	●
18	Battery indicator without hour meter	—
19	Battery capacity	85Ah●
20	Lateral change battery	—
22	Water auto-filling system	—
25	Vertical handler working	—
31	half speed function in turning	—
32	Guard arm	—
33	Fork lowered height	—
34	Special backrest	—

Note: ● standard ○ option — NA