

JX1

Medium Level Order Picker

0.5T



- High volume order picking in a warehouse environment;
- Max Platform height: 4.80m - Picking height 6.3m;
- Truck Size 1590x1500x800, turning radius (1385), suitable for narrow aisles in the warehouse;
- Strong and steady;
- AGM Battery (maintenance free), Large Lead-Acid battery as option. Simple Battery exchange.

Manufacturer			EP	EP	EP
Model designation			JX1	JX1	JX1
Drive			Electric	Electric	Electric
Load capacity	Q	kg	363	363	363
Wheelbase	y	mm	1150	1150	1256
Service weight		kg	1160	1340	1530
Height of overhead guard (cabin)	h6	mm	1590	2120	2120
Lift height	h3	mm	4030	4930	5710
Height, mast extended	h4	mm	4540	5970	6750
Overall length	l2	mm	1500	1500	1610
Overall width	b1/b2	mm	800	800	876
Stand height, elevated	h12	mm	3200	4100	4880
Turning radius	Wa	mm	1385	1385	1450
Travel speed, laden/unladen		km/h	5.5/5.5	5.5/5.5	5.5/5.5
Lifting speed, laden/unladen		m/s	0.17/0.21	0.17/0.21	0.17/0.21
Lowering speed, laden/unladen		m/s	0.35/0.26	0.35/0.26	0.35/0.26
Drive motor rating S2 60 min		kW	1.7	1.7	1.7
Battery voltage/nominal capacity		V/Ah	24V224AH	24V224AH	24V224AH

Medium Level Order Picker 0.5t

JX1

Distinguishing mark	1.1	Manufacturer			EP	EP	EP
	1.2	Model designation			JX1	JX1	JX1
	1.3	Drive			Electric	Electric	Electric
	1.4	Operator type			Order-picker	Order-picker	Order-picker
	1.5	Load capacity	Q	kg	363	363	363
Service weight	1.9	Wheelbase	y	mm	1150	1150	1256
	2.1	Service weight		kg	1160	1340	1530
	2.2	Axle loading, laden front/rear		kg	680/980	740/1100	780/1220
Tyres/chassis	2.3	Axle loading, unladen front/rear		kg	490/670	520/820	540/990
	3.1	Tyre type			Polyurethane/Solid rubber	Polyurethane/Solid rubber	Polyurethane/Solid rubber
	3.2	Tyre size, front			φ230*75	φ230*75	φ230*75
	3.3	Tyre size, rear			φ204*76	φ204*76	φ204*76
	3.4	Additional wheels (castor wheels)		mm	φ74*48	φ74*48	φ74*48
	3.5	Wheels, number front/rear (x=drive wheels)		mm	1x, 2/2	1x, 2/2	1x, 2/2
	3.6	Tread width, front	b ₁₀	mm	555	555	615
Dimensions	3.7	Tread width, rear	b ₁₁	mm	740	740	784
	4.2	Retracted mast height	h ₁	mm	1510	2080	2090
	4.4	Lift height	h ₃	mm	4030	4930	5710
	4.5	Height, mast extended	h ₄	mm	4540	5970	6750
	4.7	Height of overhead guard (cabin)	h ₆	mm	1590	2120	2120
	4.8	Seat height/standing height	h ₇	mm	250	250	250
	4.14	Stand height, elevated	h ₁₂	mm	3200	4100	4880
	4.19	Overall length	l ₁	mm	1500	1500	1610
	4.21	Overall width	b ₁ /b ₂	mm	800	800	876
	4.32	Ground clearance, center of wheelbase	m ₂	mm	50	50	50
	4.35	Turning radius	W _a	mm	1385	1385	1450
Performance data	5.1	Travel speed, laden/unladen		km/h	5.5/5.5	5.5/5.5	5.5/5.5
	5.2	Lifting speed, laden/unladen		m/s	0.17/0.21	0.17/0.21	0.17/0.21
	5.3	Lowering speed, laden/unladen		m/s	0.35/0.26	0.35/0.26	0.35/0.26
	5.10	Service brake			Electronegmatic	Electronegmatic	Electronegmatic
Electric-engine	6.1	Drive motor rating S2 60 min		kW	1.7	1.7	1.7
	6.2	Lift motor rating at S3 15%		kW	2.2	2.2	2.2
	6.4	Battery voltage/nominal capacity		V/Ah	24V224AH	24V224AH	24V224AH
	6.5	Battery weight		kg	163	163	163
Drive/lift mechanism	8.1	Type of drive control			AC	AC	AC
Addition data	10.5	Steering design			Electronic	Electronic	Electronic
	10.7	Sound pressure level at the driver's ear		dB(A)	74	74	74
	15.1	Charger output current		A	25	25	25

If there are improvements of technical parameters or configurations, no further notice will be given.
The diagram shown may contain non-standard configurations.

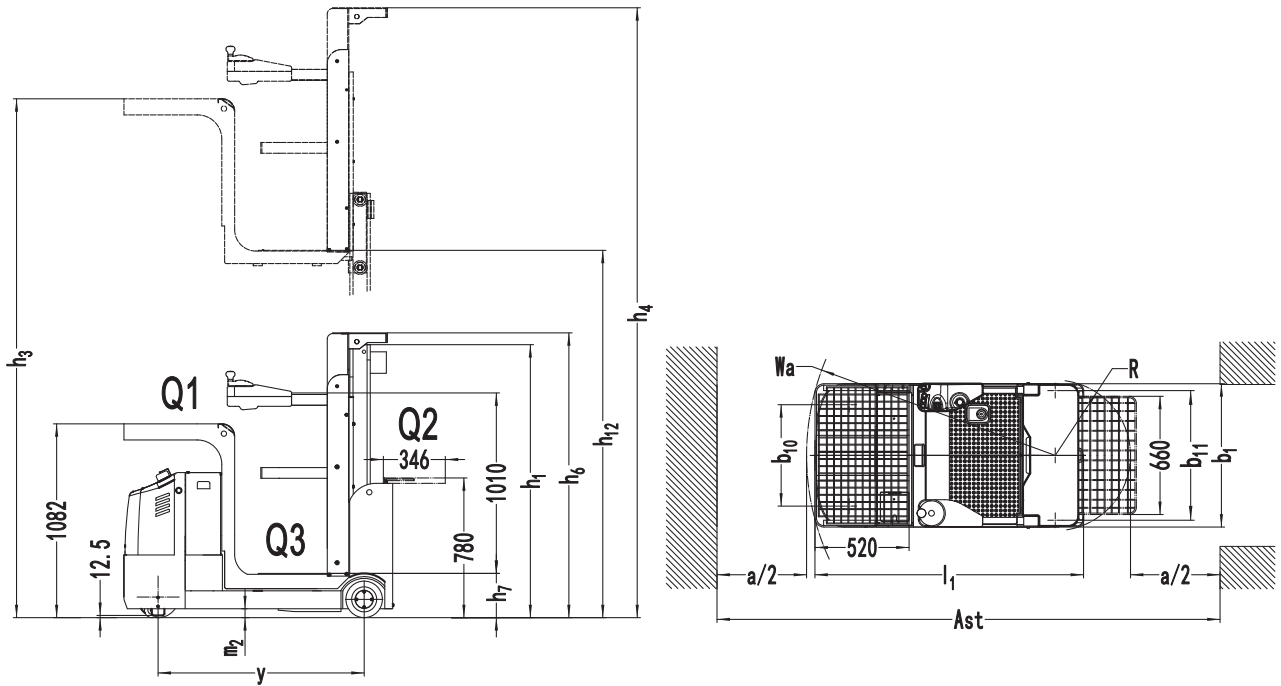

Option

No.	Optional items	JX1(3200, 4100)	JX1(4800)
2.1	Load wheel type	●Single	●Single
2.2	Load wheel material	●Rubber	●Rubber
2.3	Drive wheel material	●PU	●PU
2.7	Battery capacity	●No ○224AH ○210AH ○270AH ○205AH	●No ○224AH ○280AH ○360AH ○205AH
2.8	Charger	●No ○24V-25A Internal ○24V-40A External ○24V-27.1A Internal	●No ○24V-25A Internal ○24V-50A External ○24V-27.1A Internal
2.9	Battery indicator	●With hourmeter	●With hourmeter
2.12	Safe hook	●No ○Yes and not customized	●No ○Yes and not customized
2.13	Traction pin	●No ○Yes and not customized	●No ○Yes and not customized
2.14	Electrostatic chain	●No	●No
3.3	Castor wheels	●Yes and not customized	●Yes and not customized
3.4	Water auto-filling system	●No	●No
3.7	Warning lamp	●Front and rear warning light ○Front blue light + rear warning light ○Front blue light + front warning light	●Front and rear warning light ○Front blue light + rear warning light ○Front blue light + front warning light
3.12	Buzzer	●Drop buzzer, door alarm buzzer, dip buzzer ○Running buzzer ○Reversing buzzer	●Drop buzzer, door alarm buzzer, dip buzzer ○Running buzzer ○Reversing buzzer
3.18	Guide wheel	●No ○Yes and not customized	●No ○Yes and not customized
3.19	USB interface	●No ○Yes and not customized	●No ○Yes and not customized
4.1	Battery side pull function	●Yes and not customized	●Yes and not customized
4.7	Overhead guard	●No	●No
5.1	Battery side pull attachment	●No ○Yes and not customized	●No ○Yes and not customized
4.6	Inclinaison fourches Avant et arrière	●Yes	●Yes
5.1	Accessoire sortie latérale batterie	●No ○Side pull trolley	●No ○Side pull trolley
Note: ●Standard ○Optional - Inconformity			