



EP
Let's grow together

ES12-12MMI

Mono Mast Electric Stacker
With Initial Lift 1.2t

- Carrying Two Pallets at A Time Doubles Working Efficiency;
- Long & Aside Tiller Design Makes Operations Easy and Safe;
- Special designed four-bar linkage mechanism

EP EQUIPMENT CO.,LTD
www.ep-equipment.com



FEATURE

Performance:

- Robust Structure;
- Highly specialized drive and hydraulic system ensure excellent driving performance and high reliability;
- Low-noise and durable hydraulic unit, high quality cylinder as well as hose ensure high reliability of hydraulic system;
- AMP connector and durable electric wires greatly reduce malfunctions of components;
- C shape mast channel mast improves the strength of the whole truck;
- Dual pallets lifting doubles working efficiency.



Safety:

- Safety hydraulic design prevents mast from falling down abruptly when oil pipes cut off;
- Belly button prevents truck from hitting operator;
- By simply pressing emergency disconnect, power supply will be immediately interrupted;
- Multi lifting limited switch ensures travel safety;
- Truck automatically switches to low speed mode, when lifting height is higher than setting height;
- Anti-rolling back braking device ensures trucks don't roll back on ramps;
- Aside positioned long tiller make operator stay safe distance away from truck body.

Operation:

- Ergonomic tiller head for effortless and comfortable operations;
- Tiller with long arm for smooth steering;-
- Compact chassis design offers smallest turning radius needed;
- Side operating ensures excellent visibility;
- On-board Charger.

Maintenance:

- Maintenance-free Battery;
- Battery display indicator with hour meter, reminds operator of charging on time (optional);
- Easy Maintenance — detachable rear panel;
- Self-Diagnostics signal on the digital display allows easy trouble-shooting;
- Easy Access of Hand Set;
- Low-voltage Cut-off Protection.

Mono Mast Electric Stacker With Initial Lift 1.2t ES12-12MMI

Distinguishing mark	1.1	Manufacturer			EP
	1.2	Model designation			ES12-12MMI
	1.3	Drive			Electric
	1.4	Operator type			Pedestrian
	1.5	Load capacity	Q	kg	1200
	1.6	Load center distance	c	mm	600
	1.8	Load distance, centre of drive axle to fork	x	mm	805
	1.9	Wheelbase	y	mm	1260
	Service weight	2.1	Service weight		kg
2.2		Axle loading, laden front/rear		kg	560/1160
2.3		Axle loading, unladen front/rear		kg	350/170
Tyres/chassis	3.1	Tyre type			Polyurethane
	3.2	Tyre size, front		mm	Ø210×70
	3.3	Tyre size, rear		mm	Ø80×60
	3.4	Additional wheels (castor wheels)		mm	Ø130×55
	3.5	Wheels, number front/rear (x=drive wheels)		mm	1x +1/4
	3.6	Tread width, front	b10	mm	533
	3.7	Tread width, rear	b11	mm	370
Dimensions	4.0	Max. Lift Height	H	mm	1605
	4.2	Retracted mast height	h1	mm	1940
	4.3	Free lift	h2	mm	1480
	4.4	Lift height	h3	mm	1510
	4.5	Height, mast extended	h4	mm	2090
	4.6	Initial lift	h5	mm	115
	4.9	Height of tiller handle in drive position min./max.	h14	mm	860/ 1200
	4.10	Height of wheel arms	h8	mm	—
	4.15	Lowered height	h13	mm	95
	4.19	Overall length	l1	mm	1750
	4.20	Length to face of forks	l2	mm	600
	4.21	Overall width	b1/b2	mm	796
	4.22	Fork dimensions	s/e/l	mm	60/190/1150
	4.24	Fork carriage width	b3	mm	680
	4.25	Distance between fork-arms	b5	mm	560
	4.26	Distance between wheel arms/loading surfaces	b4	mm	—
	4.31	Ground clearance, laden, below mast	m1	mm	—
	4.32	Ground clearance, center of wheelbase	m2	mm	26
	4.34.1	Aisle width for pallets 1000×1200 crossways	Ast	mm	2340
4.34.2	Aisle width for pallets 800×1200 crossways	Ast	mm	2260	
4.35	Turning radius	Wa	mm	1500	
Performance data	5.1	Travel speed, laden/unladen		km/h	4/4.5
	5.2	Lifting speed, laden/unladen		m/s	0.10/0.14
	5.3	Lowering speed, laden/unladen		m/s	0.10/0.07
	5.8	Max. gradeability, laden/unladen		%	3/10
	5.10	Service brake			Electromagnetic
Electric-engine	6.1	Drive motor rating S2 60 min		kW	0.65
	6.2	Lift motor rating at S3 15%		kW	2.2
	6.4	Battery voltage/nominal capacity		V/Ah	2x12/85
	6.5	Battery weight		kg	2x25
Addition data	8.1	Type of drive control			DC
	10.5	Steering design			Mechanical
	10.7	Sound pressure level at the driver's ear		dB(A)	74

If there are improvements of technical parameters or configurations, no further notice will be given.
The diagram shown may contain non-standard configurations.

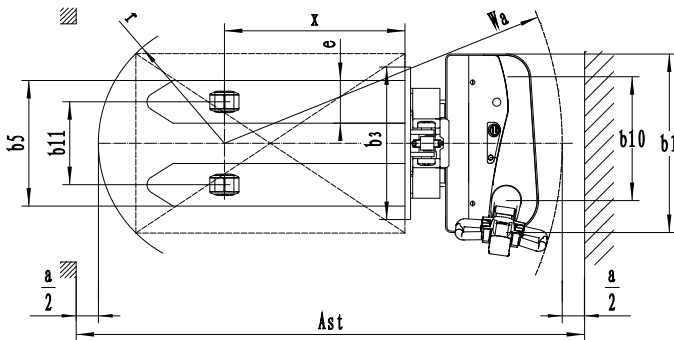
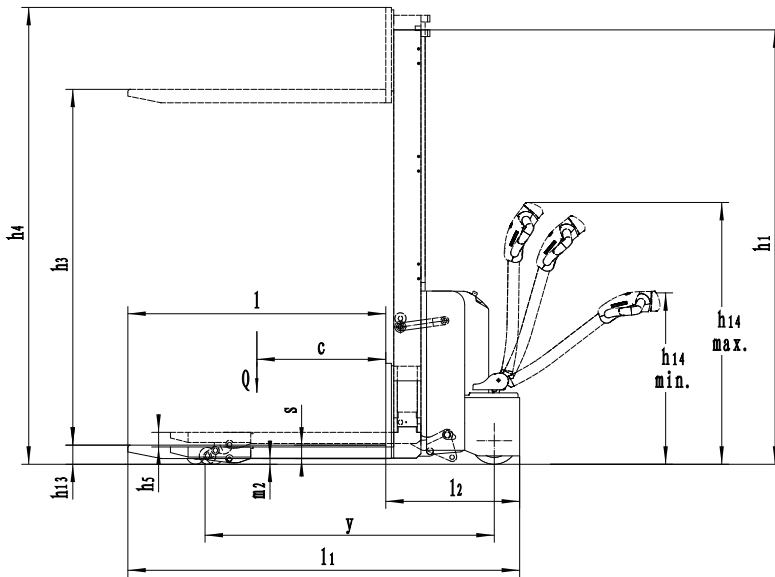

RATED CAPACITIES GRAPH

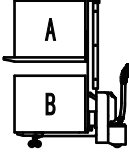
		Lift Height (mm)	Capacity (kg)
	Mast Fork A	1600	1000
		2000	800
	Support Arm B	210	A+B ≤ 1200

Mast Option

Mast types	Lift height h3+h13 (mm)	Height, mast lowered h1 (mm)	Free lift h2 (mm)	Height, mast extended h4 (mm)
2-Standard Mast	1605	1940	1606	2011
	1955	2290	1936	2361

Option

No.	Optional items	ES12-12MMI
1.1	Fork dimension	●560*1150
1.4	Fork carriage width	●680
2.1	Load wheel type	●Double
2.2	Load wheel material	●PU
2.3	Drive wheel material	●PU○Trace PU
2.7	Battery capacity	●85Ah○80Ah (Li-ion)
2.8	Charger	●24V-10A internal○24V-15A internal○24V-30A internal (Li-ion)
2.9	Battery indicator	●With time
2.16	handle head type	●Hands big handle head
3.3	Castor wheels	●Yes and not customized
3.16	Vertical handler working	●No○Yes and not customized

Note: ●Standard ○Optional - Inconformity