



# Electric Access Vehicle 118" Platform Height JX0



- Intuitive controls and driving system designed for operator ergonomics
- Low cost electric vehicle replacement for most ladder applications
- Compact size and small turning radius for usage in the tightest of spaces
- 24V lithium or optional AGM battery and on-board charger eliminating battery maintenance
- Hydraulic front work tray and locking rear gate standard
- 180° articulating driveline for zero-turn capabilities

Manufacturer			EP
Model designation			JX0
Drive			Electric
Base capacity	Q	lb.	750 lbs (340.9 kg)
	Q1	lb.	200 lbs front tray
	Q2	lb.	250 lbs front load deck
	Q3	lb.	300 lbs operator
Wheelbase	y	in.	43
Service weight		lb.	1,850
Height of operator compartment	h6	in.	54
Lift height	h3	in.	118" to platform floor+42" to tray = 160"
Height, mast extended with Std. LBR	h4	in.	118" + 43" = 161"
Overall length	l1	in.	56.5"
Overall width	b1/b2	in.	29.5"
Stand height, elevated	h12	in.	118"
Turning radius	Wa	in.	49.6
Travel speed, loaded/unloaded		mph	3.7/4
Lifting speed, loaded/unloaded		fpm	43.3/53.1
Lowering speed, loaded/unloaded		fpm	61/49.2
Max. gradeability, loaded/unloaded		%	5/8
Drive motor rating S2 60 min		kW	7
Battery voltage/nominal capacity		V/Ah	24V/120Ah AGM / 24V/135Ah Li-ion

# Electric Access Vehicle JX0

Distinguishing mark	1.1	Manufacturer				EP	EP
	1.2	Model designation				JX0	JX0
	1.3	Drive				Electric	Electric
	1.4	Operator type				Order-picker	Order-picker
1.5	Base capacity	Q	lb.			750 lbs (340.9 kg)	750 lbs (340.9 kg)
		Q1	lb.			200 lbs front tray	200 lbs front tray
		Q2	lb.			250 lbs front load deck	250 lbs front load deck
		Q3	lb.			300 lbs operator	300 lbs operator
1.9	Wheelbase	y	in.		43"	43"	
Service weight	2.1	Service weight		lb.		1850 lbs w/ battery	1850 lbs w/ battery
	2.2	Axle loading, loaded front/rear		lb.		1300.7/903.9	1300.7/903.9
	2.3	Axle loading, unloaded front/rear		lb.		837.8/925.9	837.8/925.9
Tires/chassis	3.1	Tire type				Polyurethane front Non-marking rubber rear	Polyurethane front Non-marking rubber rear
	3.2	Tire size, front				8.3" x 2.8" Poly	8.3" x 2.8" Poly
	3.3	Tire size, rear				9.8" x 3.9" NMR	9.8" x 3.9" NMR
	3.4	Additional wheels (castor wheels)		in.		2 castor wheels	2 castor wheels
	3.5	Wheels, number front/rear (x=drive wheels)		in.		1x, 2/2	1x, 2/2
	3.6	Tread width, front	b <sub>10</sub>	in.		22" caster width	22" caster width
	3.7	Tread width, rear	b <sub>11</sub>	in.		25" rear wheel width	25" rear wheel width
Dimensions	4.2	Retracted mast height	h <sub>1</sub>	in.		54"	54"
	4.3	Free lift	h <sub>2</sub>	in.		19"	19"
	4.4	Lift height	h <sub>3</sub>	in.		118" to platform floor +42" to tray = 160"	118" to platform floor +42" to tray = 160"
	4.5	Height, mast extended	h <sub>4</sub>	in.		118" + 43" = 161"	118" + 43" = 161"
	4.7	Height of operator compartment	h <sub>6</sub>	in.		54"	54"
	4.8	Seat height/standing height	h <sub>7</sub>	in.		11"	11"
	4.14	Stand height, elevated	h <sub>12</sub>	in.		118"	118"
	4.15	Lowered height	h <sub>13</sub>	in.		11"	11"
	4.19	Overall length	l <sub>1</sub>	in.		56.5"	56.5"
	4.20	Length to face of forks	l <sub>2</sub>	in.		-	-
	4.21	Overall width	b <sub>1</sub> /b <sub>2</sub>	in.		29.5"	29.5"
	4.22	Fork dimensions	s x e x l	in.		Upper Tray = 21" x 29" Load Deck = 21" x 29"	Upper Tray = 21" x 29" Load Deck = 21" x 29"
	4.25	Fork spread	b <sub>5</sub>	in.		See Fork Dim	See Fork Dim
4.32	Ground clearance, center of wheelbase	m <sub>2</sub>	in.		1.4" to frame 0.7" to stability pad	1.4" to frame 0.7" to stability pad	
4.35	Turning radius	Wa	in.		49.6	49.6	
Performance data	5.1	Travel speed, loaded/unloaded		mph			
			0" - 17.5"			4.1	4.1
			17.5" - 37"			1.9	1.9
			37" - 76"			1.3	1.3
			76" - 118"			0.6	0.6
5.2	Lifting speed, loaded/unloaded		fpm		43.3/53.1	43.3/53.1	
5.3	Lowering speed, loaded/unloaded		fpm		61/49.2	61/49.2	
5.8	Max. gradeability, loaded/unloaded		%		5/8	5/8	
5.10	Service brake				Regen, electromagnetic parking	Regen, electromagnetic parking	
Electric-engine	6.1	Drive motor rating S2 60 min		kW		0.7	0.7
	6.2	Lift motor rating at S3 15%		kW		2.2	2.2
	6.4	Battery voltage/nominal capacity		V/Ah		24V/120AH AGM	24V/135Ah Li-ion
	6.5	Battery weight		lb.		170	95
6.6	Energy consumption according to DIN EN 16796		kWh/h		- <sup>1)</sup>	- <sup>1)</sup>	
Additional data	8.1	Type of drive control				DC	DC
	10.5	Steering design				Electric	Electric
	10.7	Sound pressure level at the driver's ear		dB(A)		60	60
	15.1	Charger output current		A		15A	15A

For indoor use only. Operate on level and smooth surfaces only.

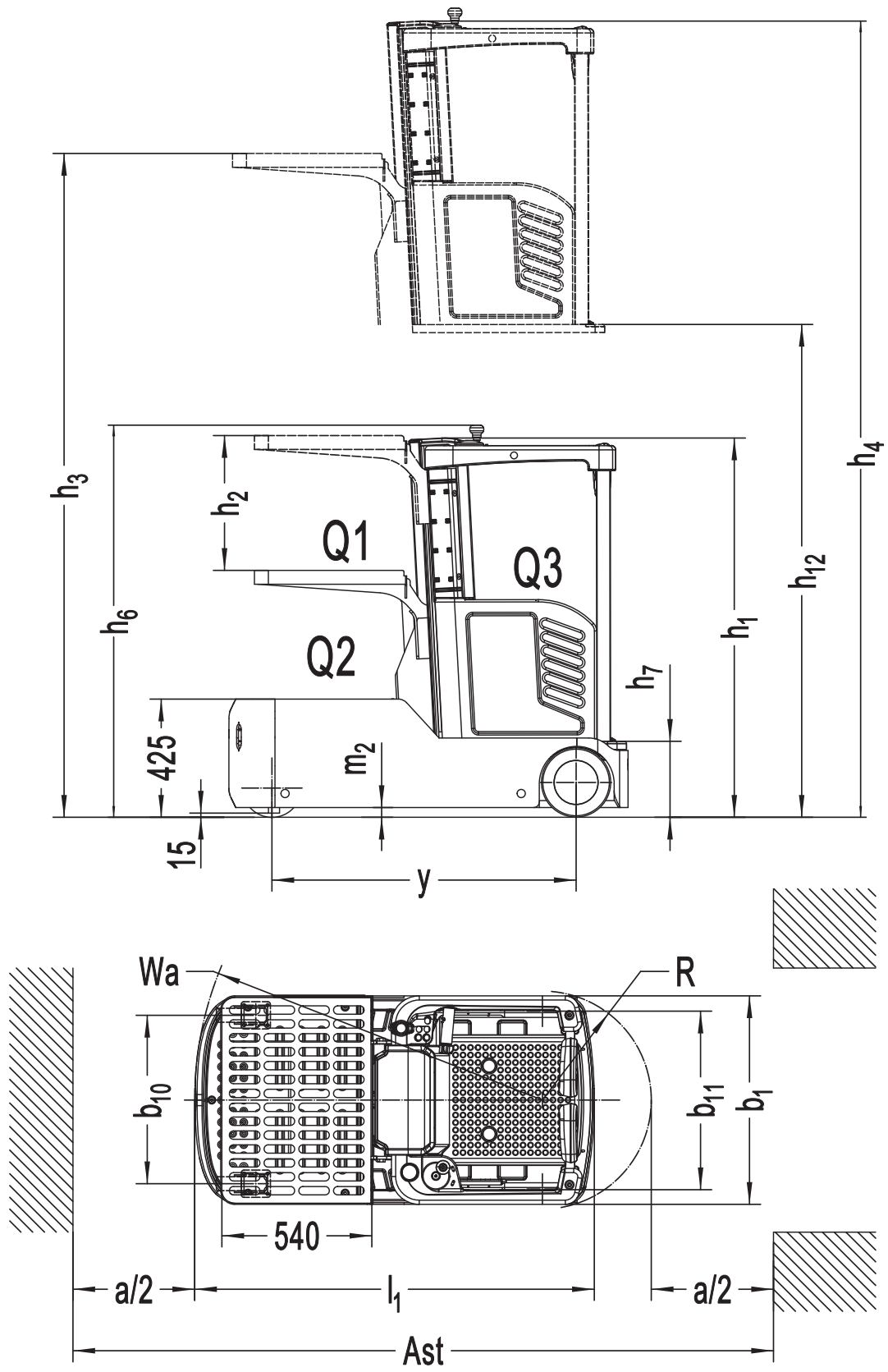



WEBSITE



**EP North America**  
4395 Diplomacy Rd  
Fort Worth, TX 76155

LINKEDIN



epforklifts.com • 833.428.0030 • sales@epforklifts.com