

EXP15

1500kg Automatic Pallet Truck

Your Simple Mover



- **World's first automatic pallet truck EXP15= EPT20-15ET+ Automation**
- **Simple Operation: Anyone can learn how to operate in 5 minutes with just 5 buttons.**
- **Simple Setup: No WiFi or complex systems needed. Touch-and-go for instant use anywhere.**
- **Simple Process: Affordable and accessible solution for businesses of all sizes starting automation.**
- **Simple Service: No specialist engineers required.**



Manufacturer			EP
Model designation			EXP15
Drive			Electric
Load capacity	Q	kg	1500
Load center distance	c	mm	600
Service weight		kg	180
Overall width	b1/b2	mm	636 (650) (700)
Fork dimensions	s/e/l	mm	55/150/1150
Turning radius	Wa	mm	1400
Max. gradeability, laden/unladen		%	5/10
Travel speed, laden/unladen		m/s	1.1/1.25
Battery voltage/nominal capacity		V/Ah	24/60
Safety protection			180° Lidar Emergency stop button Fork-tip sensor
Positioning			2D visual navigation
Parking accuracy		mm	±20
Navigation accuracy		mm	±20

FEATURE

As the first of its kind- world's first automatic pallet truck - EXP15 represents a revolution in warehouse automation. EXP15 embodies the principle of “Innovation through Simplicity” , offering a touch-and-go solution that eliminates complexity from material handling operations. As your business evolves, the EXP15 evolves with you—making it the perfect partner for anyone.



■ Simplicity

Simple Operation

One worker. Five minutes. Five buttons. That's all it takes to master the EXP15. EXP15 puts the power of automation in everyone's hands. Any worker can confidently operate it, No special training or robotics expertise needed.

Simple Sales Process

The EXP15 offers an affordable entry point into automation, ideal for businesses taking their first steps into robotics. Perfect for repetitive transport tasks, it addresses fundamental material handling needs. EXP15 is a solution for businesses of all sizes—simple enough to master quickly, yet powerful enough to solve real challenges.



Simple Setup

Free yourself from IT constraints with the EXP15' simple setup. No WiFi connection, no complex IT system, and no specialized engineers needed—just place reflectors at your start and end points for paths up to 50 meters, and you're ready to go. EXP15's touch-and-go solution makes automation accessible to all.

Simple Service

Experience maintenance as simple as an electric pallet truck, but with the capabilities of a robot. No robotics engineers or specialized technicians required.

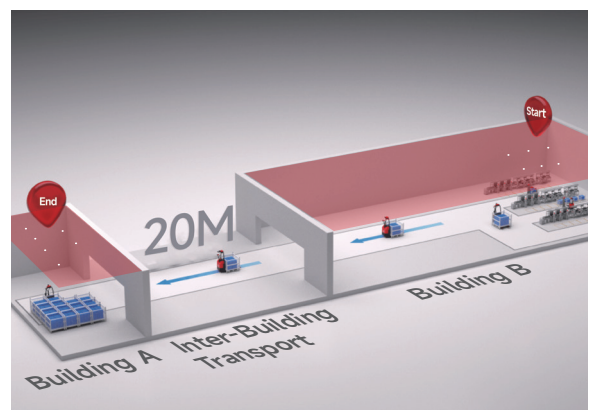

FEATURE

Safety

The EXP15 prioritizes safety without compromise. Built to meet all electric pallet truck safety standards, it goes further with dual laser protection systems—both up and down—ensuring comprehensive coverage and prevent collisions.

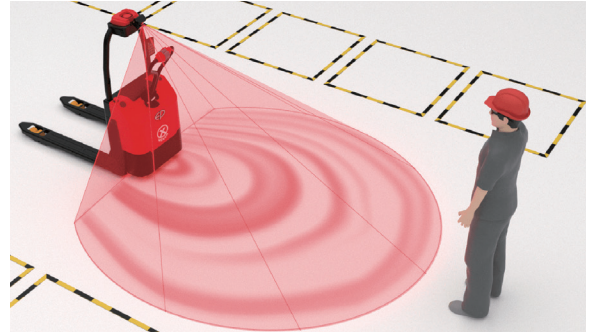

Solving labor challenge

Transform your operations from electric to automatic, reducing physical work intensity to zero. Experience dramatic cost savings with up to 80% reduction in labor expenses, while maintaining peak productivity.

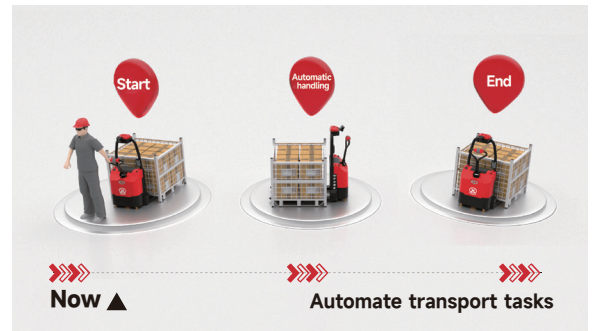

Plug-in battery design

Stay productive with smart plug-in battery design. The EXP15 features a 24V/60Ah Li-ion battery system that can be manually swapped in moments, minimizing downtime and maximizing efficiency.



1500kg Automatic Pallet Truck EXP15

Distinguishing mark	1.1	Manufacturer			EP
	1.2	Model designation			EXP15
	1.3	Drive			Electric
	1.4	Operator type			Pedestrian
	1.5	Load capacity	Q	kg	1500
	1.6	Load center distance	c	mm	600
	1.8	Load distance, centre of drive axle to fork	x	mm	950
	1.9	Wheelbase	y	mm	1120
	Service weight	2.1	Service weight		kg
2.2		Axle loading, laden front/rear		kg	1090/590
2.3		Axle loading, unladen front/rear		kg	30/150
Dimensions	4.2	Overall height	h1	mm	1420
	4.4	Lift height	h3	mm	90
	4.15	Lowered height	h13	mm	82
	4.19	Overall length	l1	mm	1620
	4.20	Length to face of forks	l2	mm	450
	4.21	Overall width	b1/b2	mm	636 (650) (700)
	4.22	Fork dimensions	s/e/l	mm	55/150/1150
	4.25	Width over the forks	b5	mm	540/600/685
	4.32	Ground clearance, center of wheelbase		mm	20
	4.34.1	Aisle width for pallets 1000×1200 crossways	Ast	mm	1860
	4.35	Turning radius	Wa	mm	1400
Performance data	5.1	Travel speed, laden/unladen		m/s	1.1/1.25
	5.2	Lifting speed, laden/unladen		m/s	0.025/0.027
	5.3	Lowering speed, laden/unladen		m/s	0.058/0.046
	5.8	Max. gradeability, laden/unladen		%	5/10
	5.10	Service brake			Electromagnetic
Electric-engine	6.1	Drive motor rating S2 60 min		kW	0.9
	6.2	Lift motor rating at S3 15%		kW	0.8
	6.4	Battery voltage/nominal capacity		V/Ah	24/60
	6.5	Battery weight		kg	14
	Addition data	8.1	Type of drive unit		
10.5		Steering design			Electric
10.7		Sound pressure level at the driver's ear		dB(A)	<74
10.11		Indoor/Outdoor			Indoor
10.12		Safety notification			Horn
10.13		Safety protection			180° Lidar Emergency stop button Fork-tip Sensor
10.14		Positioning			2D visual navigation
10.15		Parking accuracy		mm	±20
10.16		Navigation accuracy		mm	±20
10.17		Battery type			Li-ion battery

If there are improvements of technical parameters or configurations, no further notice will be given.
The diagram shown may contain non-standard configurations.

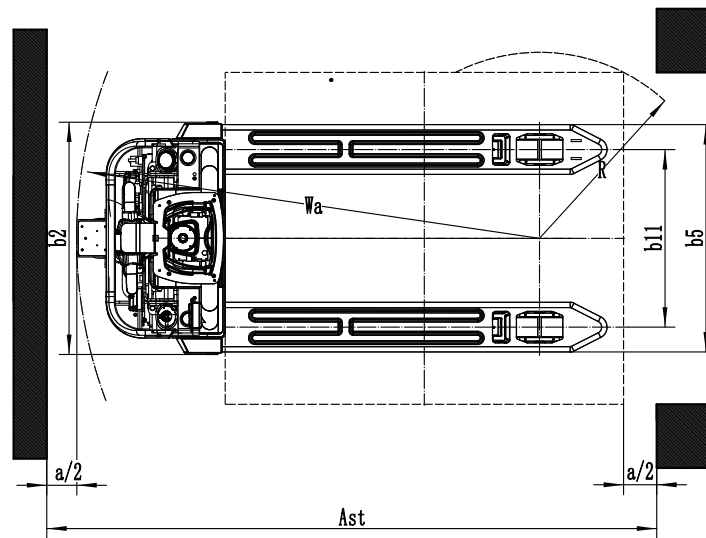
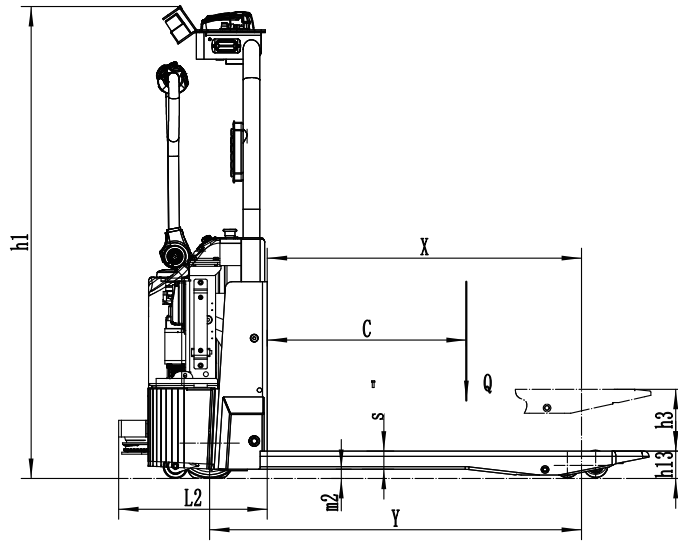

Option:

OPTIONS	EXP15
Fork length	○1000●1150○1220○1350○1400○1500
Fork width	●540○600○685
Lowered height	●82
Load wheel type	●Double○Single
Load wheel material	●PU
Drive wheel material	●PU
Battery capacity	●60AH
Charger	●24V-20A External
Battery indicator	●With hourmeter
Castor wheels	●Yes and not customized
Vertical handle: Creep speed	●Yes and not customized
Drive assembly	●Large wheel unit
Tiller head	●Double-grip large tiller
Note:	●Standard ○Optional -Inconformity



Red



Green



White

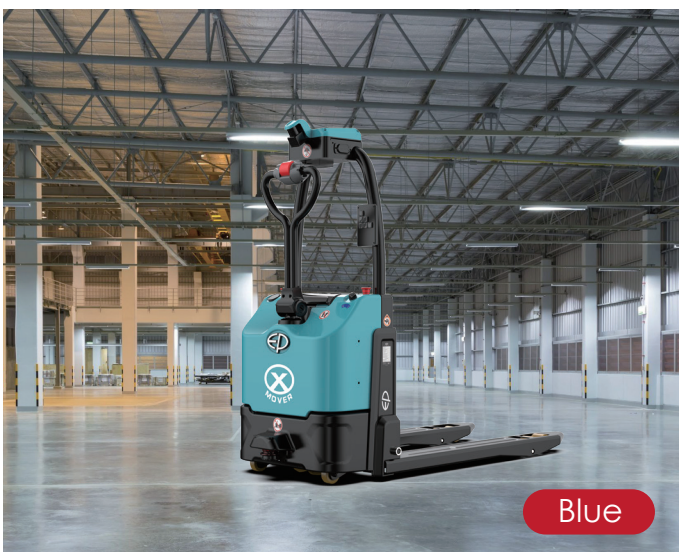

Blue



Silver